

Technical Specifications

	L20	L30
Aperture Size	20mm	30mm
Typical Scan Angle	$\pm 20^\circ$	$\pm 20^\circ$
Power Requirements	$\pm 24VDC$	$\pm 24VDC$
1% Full Scale	0.52ms	0.65ms
Marking Speed	2.5m/s	2m/s
Positioning Speed	5m/s	4m/s
Writing Speed	450cps	350cps
Repeatability	12 μ rad	12 μ rad
Gain Drift	90ppm/K	90ppm/K
Offset Drift	60 μ rad/K	60 μ rad/K
Long-term Drift	0.35mrad	0.35mrad
Operating Temperature	25°C \pm 10°C	25°C \pm 10°C
Digital Communication	XY2-100	XY2-100
Mirror Coatings	YAG/CO2/Silver	YAG/CO2/Silver
Weight	2.62kg	3.12kg

Drawing for L20

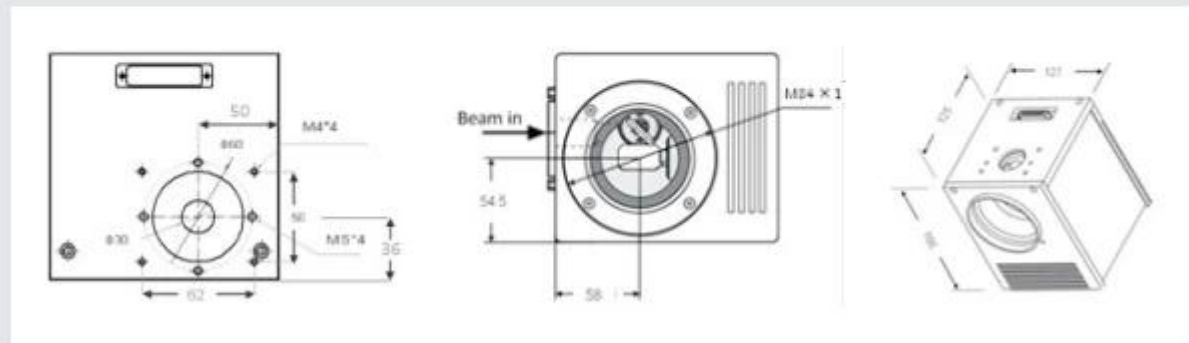



Galvanometer Scanner

Trade Shows

2014



2015



2016

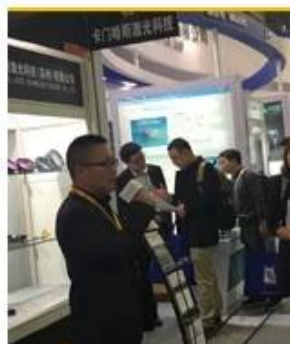
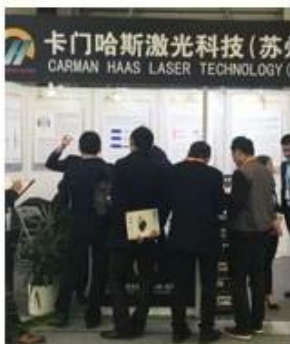

Packaging & Shipping

Packaging 1



Packaging 2



Packaging 3



Shipping 4



