

Carmanhaas 1000

Carmanhaas 1000 is a high-quality optical filter designed for precision applications. It features a multi-layer dielectric coating that provides excellent performance across a wide range of wavelengths. The filter is available in various sizes and thicknesses to meet your specific requirements.

Key features include:

- (1) High optical density and low reflectance
- (2)  $\lambda / 5$  bandwidth
- (3) 15000 cycles of operation
- (4) 20% transmission, long life time
- (5) 0.2  $\mu\text{m}$  surface roughness



Technical specifications and performance data

Key specifications:

Technical specifications	
Optical density	High optical density
Bandwidth	+0.000 "-0.005"
Surface roughness	$\pm 0.01$ "
Transmission	40-20.
Surface roughness (RMS)	$\leq 1$ $\mu\text{m}$

Additional information:

□□□□	
1070 @ □□□□ □□□□□□□□ □□□ □□□□nm	
□□□□□□ □□□□□□	< 100PPM
□□□□□□□□	> 99.9□

□□□□□□□□ □□□□□ □□□□□ □□□□□□:

□□) □□□□□□	□□) □□□□□□ □□□□□□	□□□□
18.	2.	AR / AR @ 1030-1090nm
20.	2/3/4.	AR / AR @ 1030-1090nm
21.5.	2.	AR / AR @ 1030-1090nm
22.35.	4.	AR / AR @ 1030-1090nm
24.9.	1.5.	AR / AR @ 1030-1090nm
25.4.	4.	AR / AR @ 1030-1090nm
27.9.	4.1.	AR / AR @ 1030-1090nm
30.	1.5 / 5.	AR / AR @ 1030-1090nm
32.	2/5.	AR / AR @ 1030-1090nm
34.	5.	AR / AR @ 1030-1090nm
35.	4.	AR / AR @ 1030-1090nm
37.	1.5 / 1.6 / 7	AR / AR @ 1030-1090nm
38.	1.5 / 2 / 6.35	AR / AR @ 1030-1090nm
40.	2 / 2.5 / 3/5	AR / AR @ 1030-1090nm
45.	3.	AR / AR @ 1030-1090nm
50.	2/4.	AR / AR @ 1030-1090nm
80.	4.	AR / AR @ 1030-1090nm

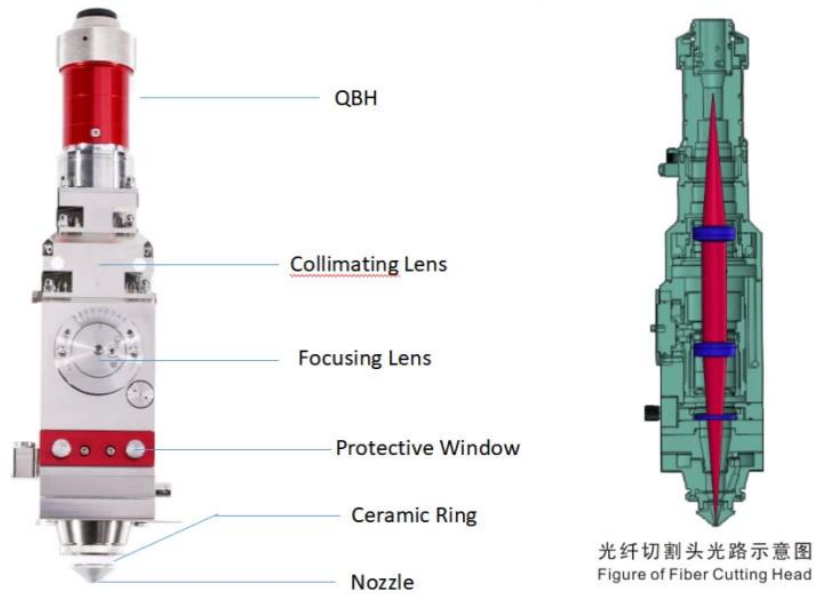

## Installation Diagram

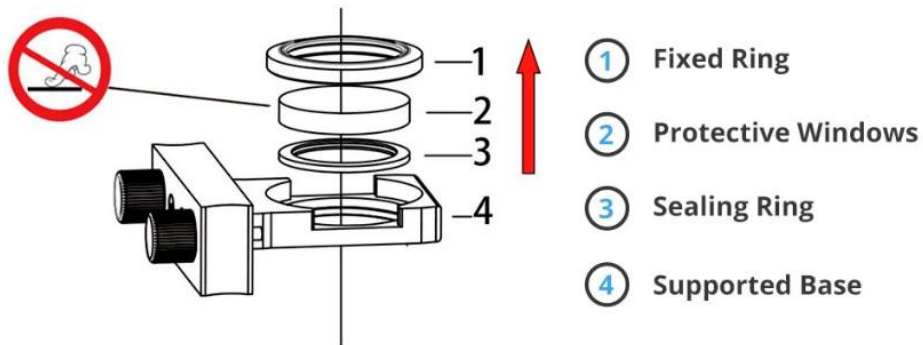

**NOTICE:** 1—3 Parts Should be taken out in the direction of the arrow, otherwise these parts will be damaged.





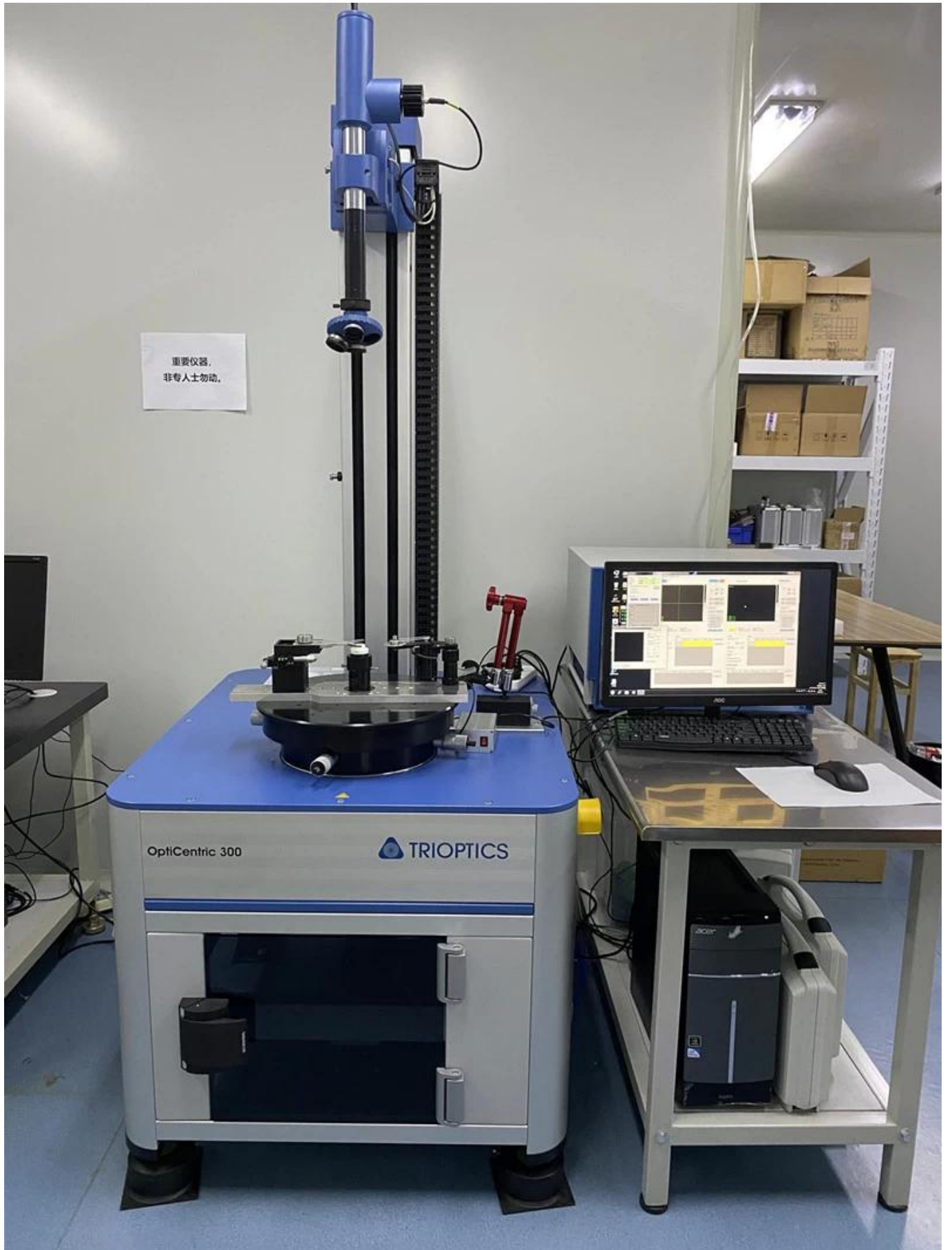

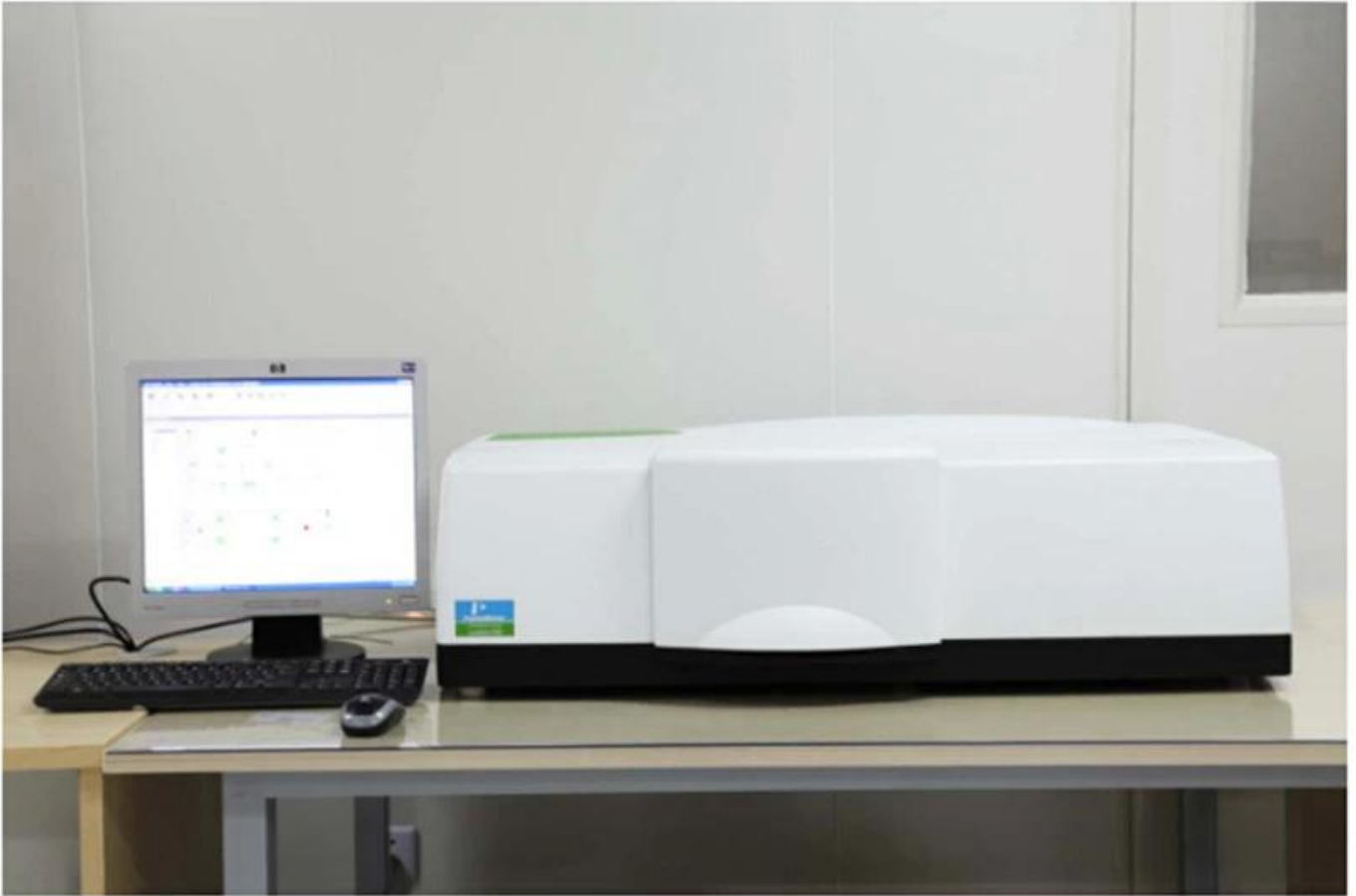

PerkinElmer Lambda 950---Testing Transmission and Reflectivity



□□□□ □□□□







# CERTIFICATE

## ATTESTATION CERTIFICATE OF MACHINERY AND LOW VOLTAGE DIRECTIVES

Technical file of the company mentioned below has been observed and audit has been completed successfully. 2006/42/EC Machinery Directive and 2014/ 35/EU Low Voltage Directive have been taken as references for these processes

Company Name : **Camman HAAS Laser Technology (Suzhou) Co., Ltd.**

Company Address : No 155, West Road Suhong, Suzhou Industrial Park, Suzhou City, Jiangsu , P.R.China

Related Directives and Annex : **Low Voltage Directive 2014/35/EU  
Machinery Directive 2006/42/EC**

Related Standards : **EN ISO 12100:2010; EN 60204-1:2006+A1:2009+AC:2010**

Product Name : **Laser Marking Machine**

Report No and Date : SD-90049717.09.08.2018

Product Brand/Model/Type : LMCH-3W,LMCH-5W,LMCH-10W,LMCH-15W,LMCH-20W,LMCH-25W,  
LMCH-30W,LMCH-50W,LMCH-60W,LMCH-70W,LMCH-100W,  
LMCH-120W,LMCH-150W,LMCH-200W,LMCH-300W,LMCH-500W

Certificate Number : **M.2018.201.N6073**

Initial Assessment Date : 10.08.2018

Registration Date : 13.08.2018

Reissue Date/No :

Expiry Date : **12.08.2023**

*Signature*  
UDEM International Certification  
Auditing Training Centre Industry  
and Trade Inc. Co.



The validity of the certificate can be checked through [www.udem.com.tr](http://www.udem.com.tr). The CE mark shown on the right can only be used under the responsibility of the manufacturer with the completion of EC Declaration of Conformity for all the relevant Directives. This certificate remains the property of UDEM International Certification Auditing Training Centre Industry and Trade Inc. Co. to whom it must be returned upon request. The above-mentioned firm must keep a copy of this certificate for 15 years from the registration of certificate. This certificate only covers the product(s) stated above and UDEM must be notified in case of any changes on the product(s).  
Address: Mithakere Mahalleli 2073 Sokak (Eski 93 Sokak) No:10 Çankaya - Ankara - TÜRKİYE  
Phone: +90 0312 443 03 90 Fax: +90 0312 443 03 76  
E-mail: [info@udemtd.com.tr](mailto:info@udemtd.com.tr) [www.udem.com.tr](http://www.udem.com.tr)



## Certificate of Approval

Certificate No.: 10119Q12565R0M

Awarded to

**Carman Haas Laser Technology(SuZhou)  
Co., Ltd.**

Organization Code Certificate No. / Unified Social Credit Code:91320594MA1MF4EP56  
Add.:No.155, West Road Suhong, Suzhou Industrial Park, Suzhou City, Jiangsu Province, P.R. China. 215000

Beijing ZhongLianTianRun Certification Center (ZLTR) certify that the  
Quality Management System of the above organization has been assessed and found to be  
in accordance with the requirements of the standard:  
**GB/T19001-2016 / ISO9001:2015**

### SCOPE OF CERTIFICATION/REGISTRATION

The Research and Development and Production of Optics Lenses (Except the limits of national laws and regulations.)

This certificate is made valid when used with certification scopes and the requirements of applicable laws and regulations. These requirements include, but are not limited to, administrative permits, scopes of qualifications, and CCC requirements.

Subject to operation conditions in requirements conformity with Quality Management System.

This Certificate is valid for a period of three years only.

**Date from: Mar 13th,2019 To: Mar 12th,2022**

The effectiveness of this Certificate shall be Validated by periodic surveillance audit of ZLTR for maintenance.

Information of this certificate can be found on the official website of Beijing Zhonglian Tianrun Certification center (<http://www.zltr.com.cn>)



Beijing ZhongLianTianRun Certification Center

Room2003, 22nd Floor, 2nd Unit, Block 1, No.4 Yard, Qiyang Road, Chaoyang District, Beijing, P.R. China 100022

Information of the center can be found on the official website of Certification and Accreditation Administration of the People's Republic of China (<http://www.cca.gov.cn>)

ISO 9001

ISO 9001



□□□□□□□□□□



# Packaging & Shipping

## Packaging 1



## Packaging 2



## Packaging 3



## Shipping 4



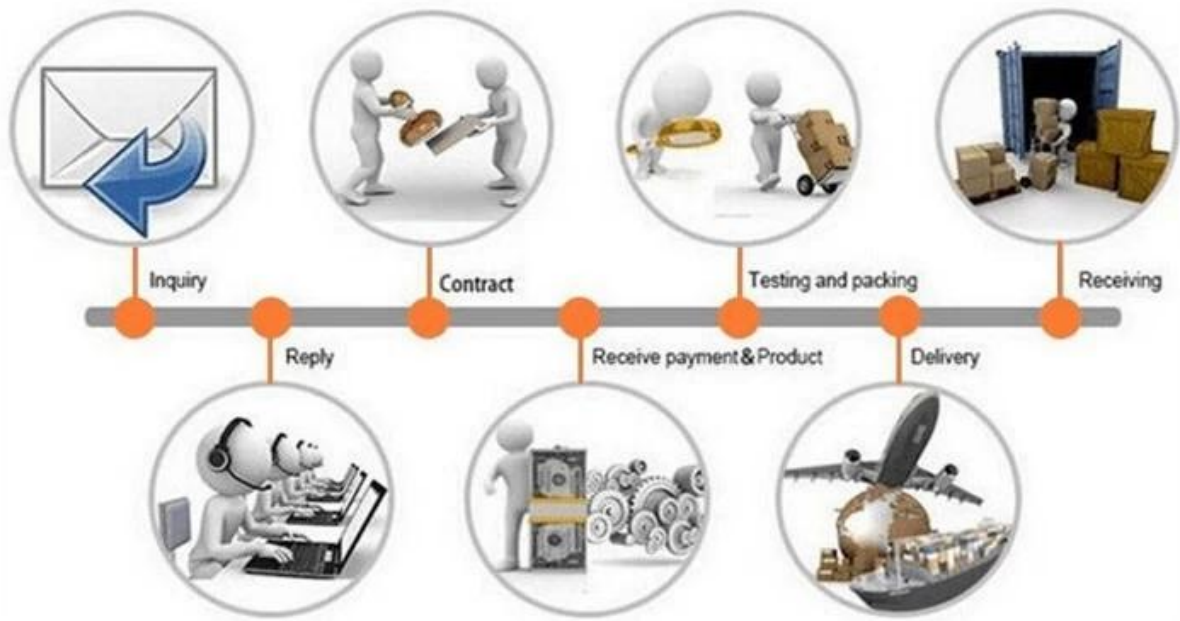

□□□□□□□□ □□□□□:

- : 1. 2. 3. 4.
- . 1.
- . 2.
- . 3.
- . 4.

1. 2. 3. 4.

- (1) dhl ups tnt ems ets
- (2) CNF CIF

1. 2. 3. 4.

**Q1.**

A1:

**Q2.How**

A2:

**Q3.How**

A3:

**Q4.How**

A4:

**Q5.May**

A5:

**q6.can**

A6:

**Q7.How OEM ODM**

A7:

**q8.**

A8: