

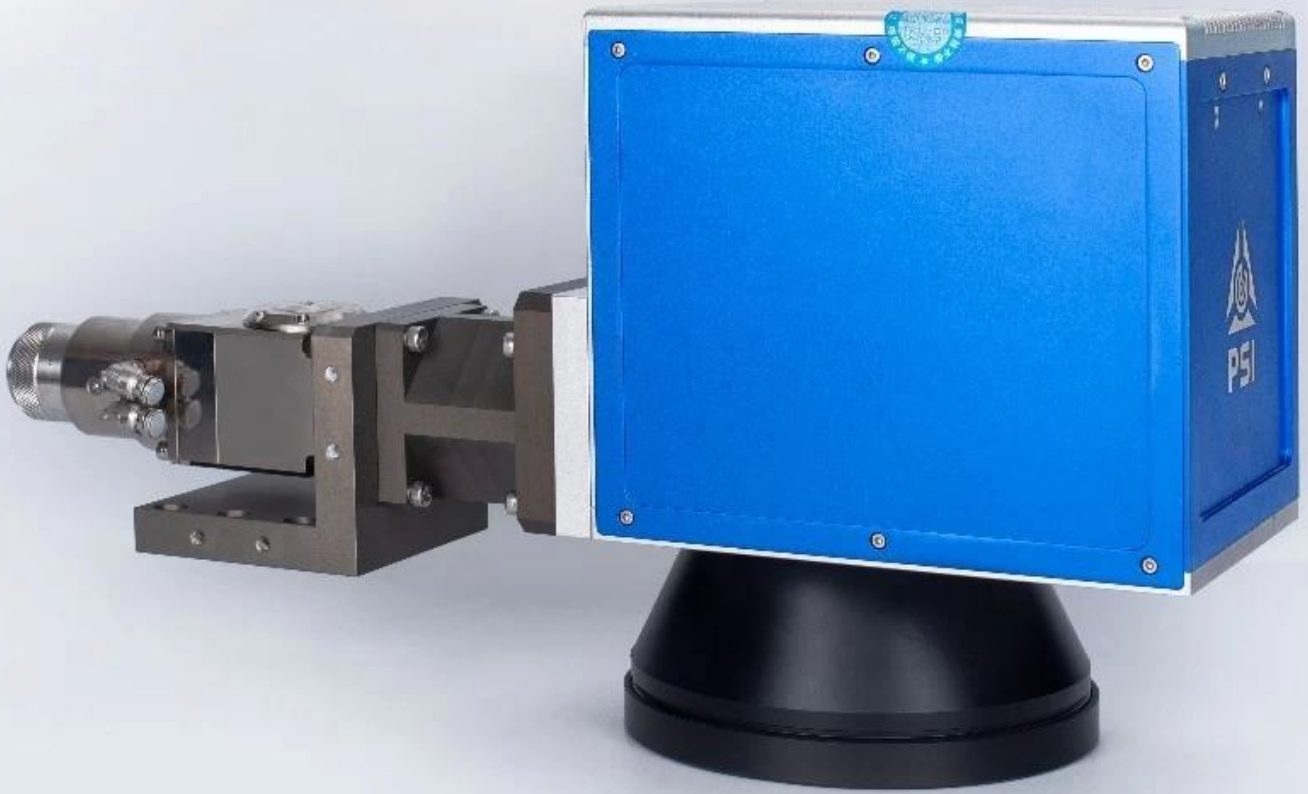

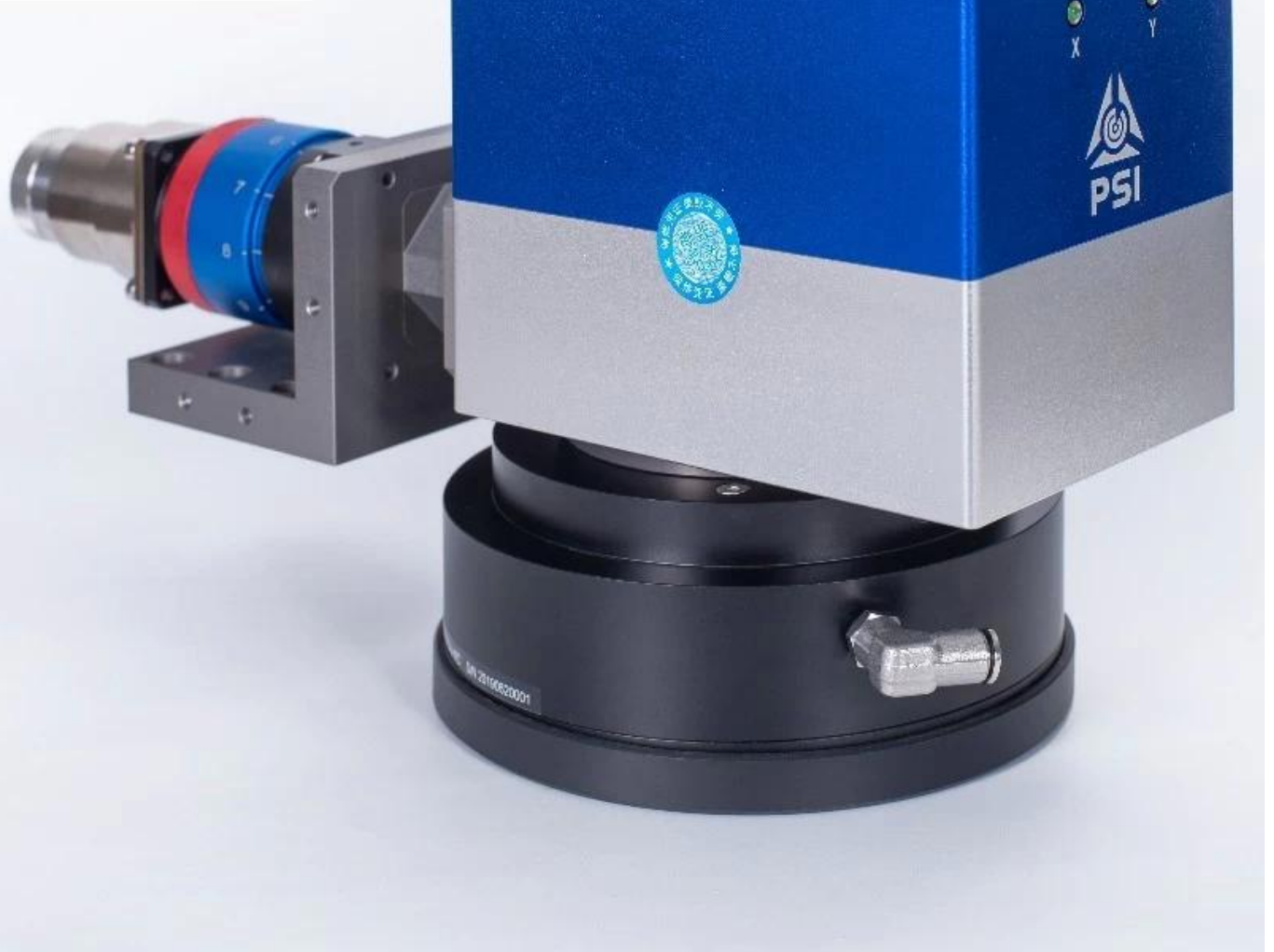

CARMAN HAAS





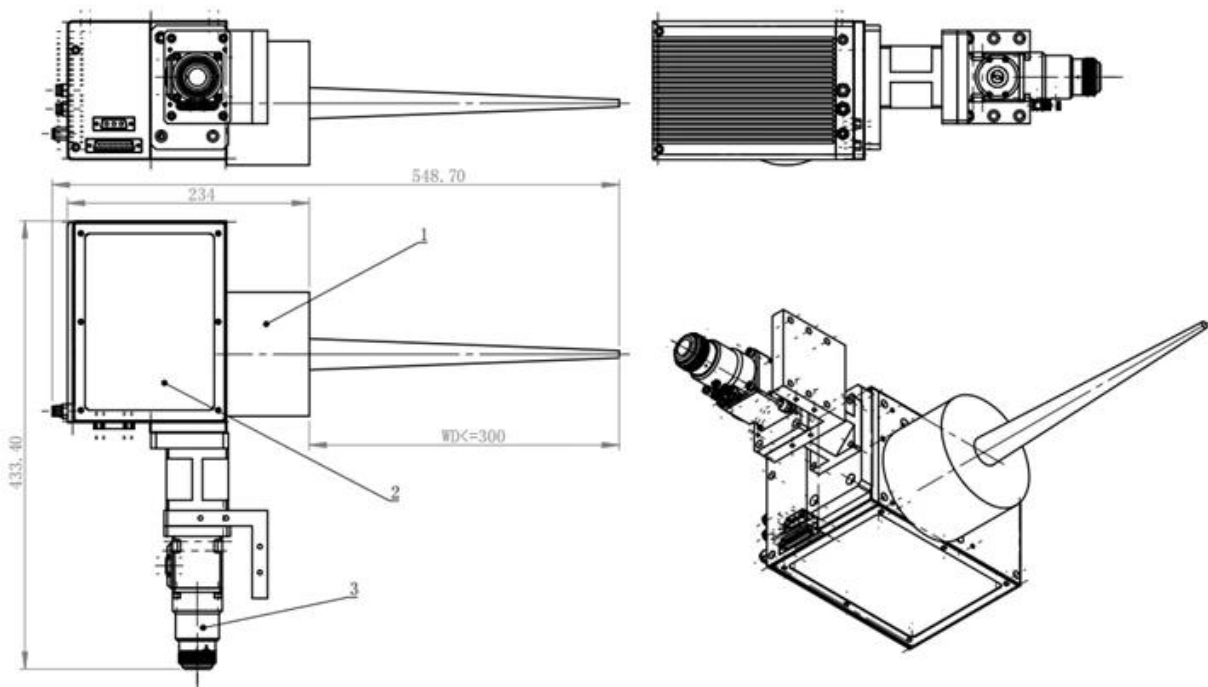

□□□□□□ □□□□□□□□



□□□□□	PSH14HW.	PSH20HW.
□□□□□□ □□ □□□□□□□ □□□□□□□□□□□□ □□□ 1))	1000W.	2000W.
1) □□□□□□ □□□□□□□ □□□□□□□ □□□□)	30J / CM2.	30J / CM2.
□□□□□□	□□□□□□ □□□□□□	□□□□□□ □□□□□□
□□) □□□□)	14.	20.
2) □□□□□□□ □□□□□ □□□□□)	± 12 °	± 12 °
□□□□□□ □□□□□□□	≤ 0.2ms.	≤ 0.28ms.
□□□□□□ □□□□□□ □□ □1) □□□□□□ □□□□□□□ □□□)	≤ 0.4 □□□□□□□	≤ 0.7 □□□□□□□
3) □□□□□□ / □□□□□□□ □□□□□)	< 15 m/s	< 9 m/s
4) □□□□□□□ □□□□□□□ □□□□)	< 3 m/s	< 2 m/s
4) (3) □□□□□□ □□□□□□□ □□□□)	650 CPS.	450 CPS.
4) (3) □□□□□□□ □□□□□□□ □□□□)	500 CPS.	300 CPS.
□□□□□□	99.9□	99.9□
□□□□□□□□	≤ 3 Urad.	≤ 3 Urad.
□□□□□□ □□□ □□□□□□□ □□□□□□□ □□□□□ 8 □□ □□□□□ □□□□□□□ □□□□□□ 10 □□□□) □□□□□□□)	≤ 30 Urad.	≤ 30 Urad.
□□□□□□□□ □□□□□ □□□□□ □□□□□ □□□□□ 8 □□ □□□□□ □□□□□□□ □□□□□□ 10 □□□□)	≤ 30 Urad.	≤ 30 Urad.
□□□□□□□ □□□□□□□ □□□□□	25 °C ± 10 °C	25 °C ± 10 °C
□□□□□□□ □□□□□□	10 ± :□□□□□□□□□□V □□□□□□□□□ :□□□□□□□□ XY2-100	10 ± :□□□□□□□□□□V □□□□□□□□□ :□□□□□□□□ XY2-100

± 15V @ 4A rms	± 15V @ 4A rms
----------------	----------------

:  
 1090-1030 (1)nm.

(2) .

(3) F-Theta F = 163mm. .

. (4)

(5).

**QBH (1030NM - 1090nm):**

Part Description	Focal Length (mm)	Clear Aperture (mm)	NA	Coating
CL2-(1030-1090)-30-F60-QBH-A-WC	60	28	0.22	AR/AR@1030-1090nm
CL2-(1030-1090)-30-F75-QBH-A-WC	75	28	0.17	AR/AR@1030-1090nm
CL2-(1030-1090)-30-F100-QBH-A-WC	100	28	0.13	AR/AR@1030-1090nm
CL2-(1030-1090)-30-F125-QBH-A-WC	125	28	0.1	AR/AR@1030-1090nm
CL2-(1030-1090)-30-F150-QBH-A-WC	150	28	0.09	AR/AR@1030-1090nm

:  
 BBP

**1030nm - 1090nm F-Theta Lens:**

Part Description	Focal Length (mm)	Scan Field (mm)	Max Entrance Pupil (mm)	Working Distance(mm)	Mounting Thread
SL-(1030-1090)-105-170-(15CA)	170	105x105	15	215	M85x1
SL-(1030-1090)-150-210-(15CA)	210	150x150	15	269	M85x1
SL-(1030-1090)-175-254-(15CA)	254	175x175	15	317	M85x1
SL-(1030-1090)-180-340-(30CA)-M102*1-WC	340	180x180	30	417	M102x1
SL-(1030-1090)-180-400-(30CA)-M102*1-WC	400	180x180	30	491	M102x1
SL-(1030-1090)-250-500-(30CA)-M112*1-WC	500	250x250	30	607	M102x1

: \* WC

အောက်ဖော်ပြပါ ပုံများကို ကြည့်ရှုပြီး ပုံစံများကို အတိုင်း ပြုပြင်ဆောင်ရွက်ပါ။ အောက်ဖော်ပြပါ ပုံများကို ကြည့်ရှုပြီး ပုံစံများကို အတိုင်း ပြုပြင်ဆောင်ရွက်ပါ။ အောက်ဖော်ပြပါ ပုံများကို ကြည့်ရှုပြီး ပုံစံများကို အတိုင်း ပြုပြင်ဆောင်ရွက်ပါ။ အောက်ဖော်ပြပါ ပုံများကို ကြည့်ရှုပြီး ပုံစံများကို အတိုင်း ပြုပြင်ဆောင်ရွက်ပါ။

အောက်ဖော်ပြပါ ပုံများကို ကြည့်ရှုပြီး ပုံစံများကို အတိုင်း ပြုပြင်ဆောင်ရွက်ပါ။

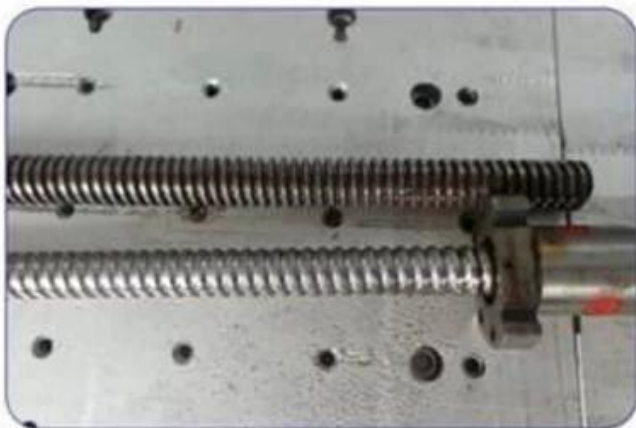
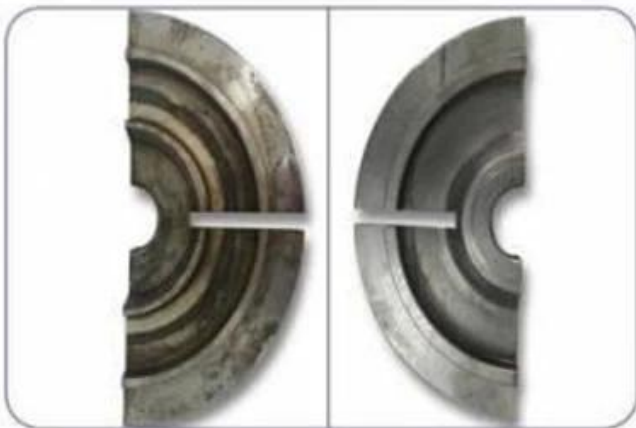

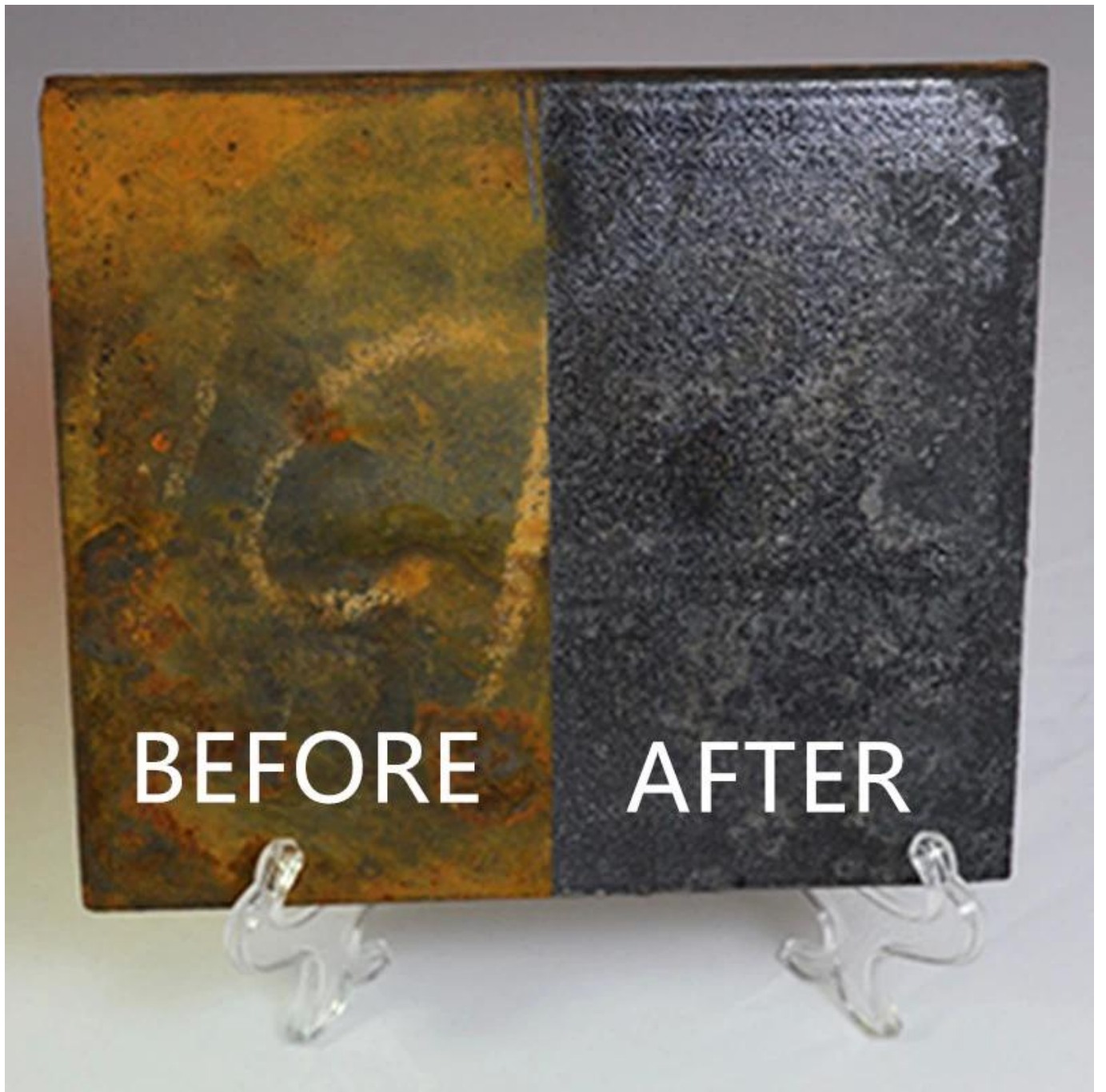

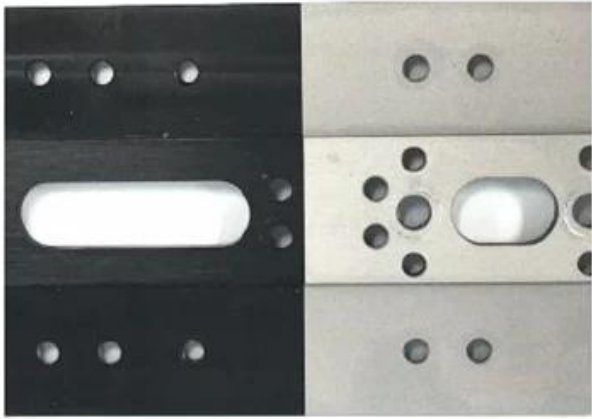

BEFORE

AFTER



BEFORE

AFTER



BEFORE



AFTER



BEFORE

AFTER







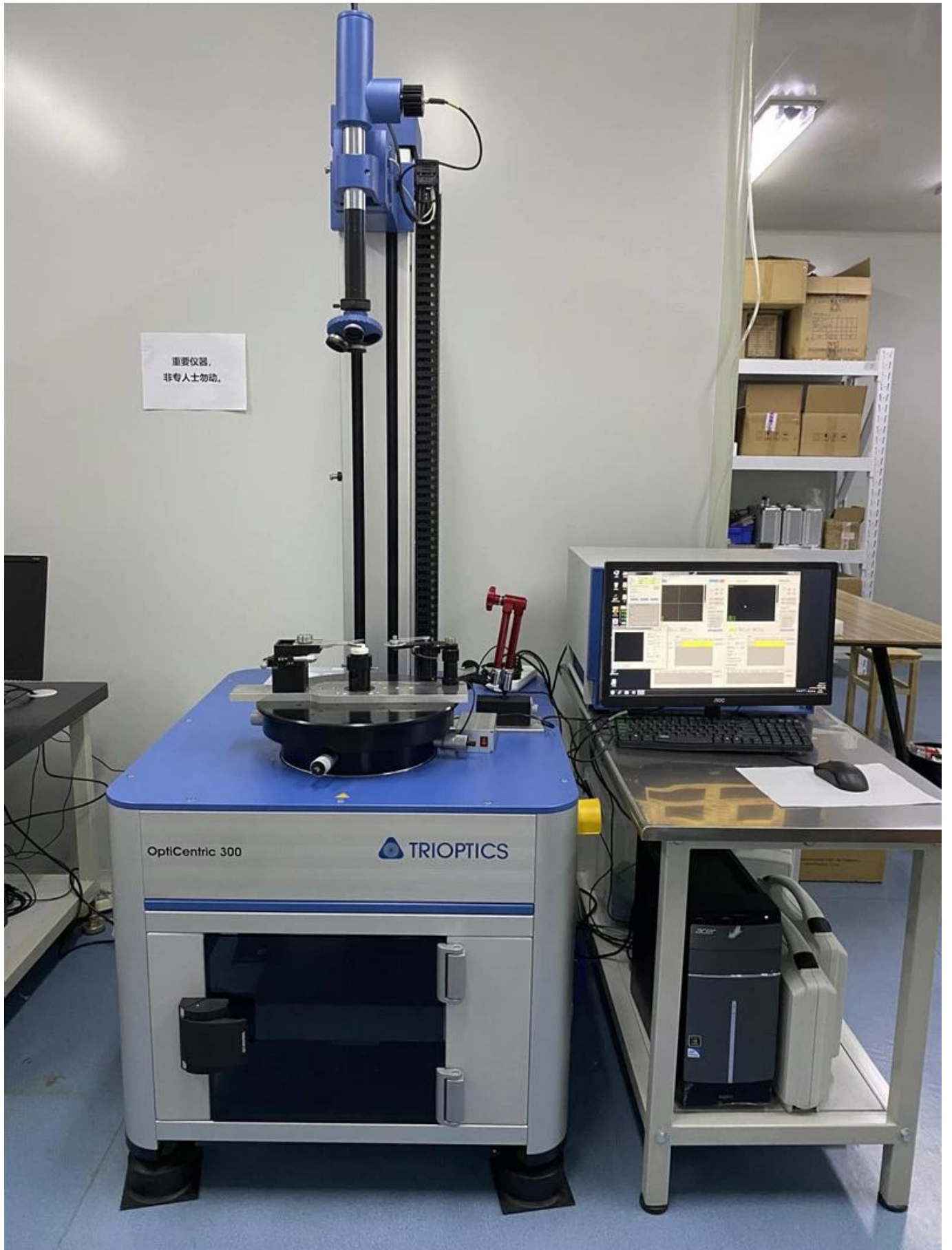

重要仪器,  
非专业人士勿动。

OptiCentric 300

TRIOPTICS



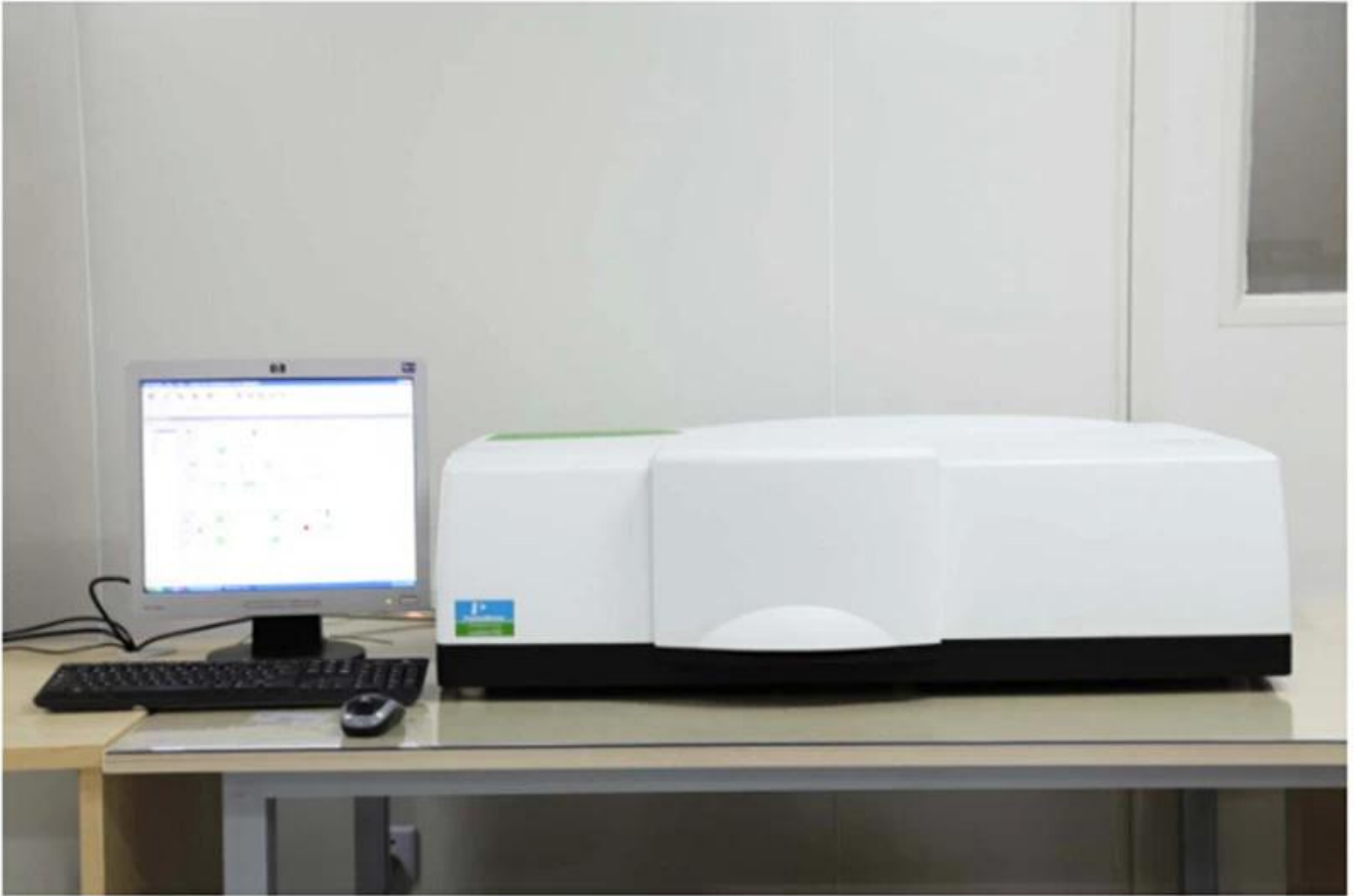

PerkinElmer Lambda 950---Testing Transmission and Reflectivity



□□□□ □□□□





# C E R T I F I C A T E

## ATTESTATION CERTIFICATE OF MACHINERY AND LOW VOLTAGE DIRECTIVES

Technical file of the company mentioned below has been observed and audit has been completed successfully. 2006/42/EC Machinery Directive and 2014/35/EU Low Voltage Directive have been taken as references for these processes

Company Name : **Camman HAAS Laser Technology (Suzhou) Co., Ltd.**

Company Address : No 155, West Road Suhong, Suzhou Industrial Park, Suzhou City, Jiangsu , P.R.China

Related Directives and Annex : **Low Voltage Directive 2014/35/EU  
Machinery Directive 2006/42/EC**

Related Standards : **EN ISO 12100:2010; EN 60204-1:2006+A1:2009+AC:2010**

Product Name : **Laser Marking Machine**

Report No and Date : **SD-90049717.09.08.2018**

Product Brand/Model/Type : **LMCH-3W,LMCH-5W,LMCH-10W,LMCH-15W,LMCH-20W,LMCH-25W,  
LMCH-30W,LMCH-50W,LMCH-60W,LMCH-70W,LMCH-100W,  
LMCH-120W,LMCH-150W,LMCH-200W,LMCH-300W,LMCH-500W**

Certificate Number : **M.2018.201.N6073**

Initial Assessment Date : **10.08.2018**

Registration Date : **13.08.2018**

Reissue Date/No :

Expiry Date : **12.08.2023**

*U. Singh*  
UDM International Certification  
Auditing Training Centre Industry  
and Trade Inc. Co.

The validity of the certificate can be checked through [www.udem.com.tr](http://www.udem.com.tr). The CE mark shown on the right can only be used under the responsibility of the manufacturer with the completion of EC Declaration of Conformity for all the relevant Directives. This certificate remains the property of UDEM International Certification Auditing Training Centre Industry and Trade Inc. Co. to whom it must be returned upon request. The above named firm must keep a copy of this certificate for 10 years from the registration of certificate. This certificate only covers the product(s) stated above and UDEM must be notified in case of any changes on the product(s).  
Address: Mithakeet Mahabul 2073 Sokak (Eski 93 Sokak) No:10 Çankaya - Ankara - TÜRKİYE  
Phone: +90 0312 443 03 90 Fax: +90 0312 443 03 76  
E-mail: [info@udemtd.com.tr](mailto:info@udemtd.com.tr) [www.udem.com.tr](http://www.udem.com.tr)



## Certificate of Approval

Certificate No.: 10119Q12565R0M

Awarded to

**Carman Haas Laser Technology(SuZhou)  
Co., Ltd.**

Organization Code Certificate No. / Unified Social Credit Code:91320594MA1MF4EP56  
Add.No.155, West Road Suhong, Suzhou Industrial Park, Suzhou City, Jiangsu Province, P.R. China. 215000

Beijing ZhongLianTianRun Certification Center (ZLTR) certify that the  
Quality Management System of the above organization has been assessed and found to be  
in accordance with the requirements of the standard:  
**GB/T19001-2016 / ISO9001:2015**

### SCOPE OF CERTIFICATION/REGISTRATION

The Research and Development and Production of Optics Lenses (Except the limits of national laws and regulations.)

This certificate is made valid when used with certification scopes and the requirements of applicable laws and regulations. These requirements include, but are not limited to, administrative permits, scopes of qualifications, and CCC requirements.

Subject to operation conditions in requirements conformity with Quality Management System,

This Certificate is valid for a period of three years only,

**Date from: Mar 13th,2019 To: Mar 12th,2022**

The effectiveness of this Certificate shall be Validated by periodic surveillance audit of ZLTR for maintenance.

Information of this certificate can be found on the official website of Beijing Zhonglian Tianrun Certification center (<http://www.zltr.com.cn>)



Beijing ZhongLiantianrun Certification Center

Room2003, 22nd Floor, 2nd Unit, Block 1, No.4 Yard, Qiyang Road, Chaoyang District, Beijing, P.R. China 100022

Information of the center can be found on the official website of Certification and Accreditation Administration of the People's Republic of China (<http://www.cnca.gov.cn>)

ISO 9001

ISO 9001



□□□□□ □□□□□□□□ □□□□□□□□



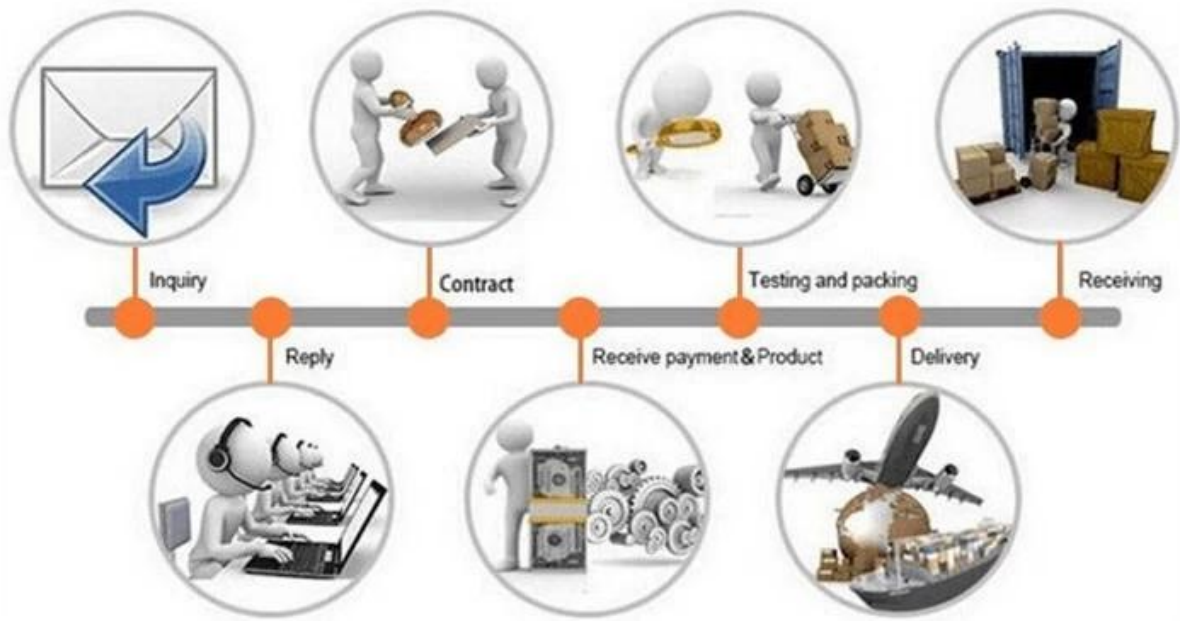

□□□□□□ □□□□:



- : 1. 2. 3. 4.

1. 2. 3. 4.

- (1) dhl ups tnt ems ets
- (2) CNF CIF

1. 2. 3. 4.

**Q1.** 1. 2. 3. 4.

A1: 1. 2. 3. 4.

**Q2.How** 1. 2. 3. 4.

A2: 1. 2. 3. 4.

**Q3.How** 1. 2. 3. 4.

A3: 1. 2. 3. 4.

**Q4.How** 1. 2. 3. 4.

A4: 1. 2. 3. 4.

**Q5.May** 1. 2. 3. 4.

A5: 1. 2. 3. 4. !

**q6.can** 1. 2. 3. 4.

A6: 1. 2. 3. 4.

**Q7.How** 1. 2. 3. 4. **OEM** **ODM**

A7: 1. 2. 3. 4. OEM / ODM ORDerS. 1. 2. 3. 4.

**q8.** 1. 2. 3. 4.

A8: 0000 00 00000 00000 T / T 000 000 00000000 0000 0000000 00000 00000 00000.