

# Produktinformation

## Produktbeschreibung:

Laserkeramik für Faserschneidkopf ([Laserschneidendüse Lieferanten](#))

Tippe A:

28mm (OEM Precinec P0571-1051-00001)

Außendurchmesser: 28 / 24,5 mm Dicke: 12mm

Typ B:

28mm (OEM Prectec P0571-260-00001)

Außendurchmesser: 28 / 24,5 mm Dicke: 12mm

Typ C:

32mm (OEM Raytools BT240 / BM109)

Außendurchmesser: 32/28,5 mm Dicke: 12mm

## Produktmerkmale:

- (1) Importierte Keramik, effektive Isolierung, lange Lebensdauer
- (2) Hochwertige Sonderlegierungen, gute Leitfähigkeit, hohe Empfindlichkeit
- (3) Glatte Linien, hohe Isolierung



**Features**

Complete specifications, Spot sale.  
 Long life time, Not easy to crack, Not easily stained with ash.  
 Low Loss Anti-reflectanc, High Efficiency.  
 CNC milling and turning, drilling, grinding, tapping, high accuracy and small error.  
 100% inspection before shipment, quality assurance.

**Product Details**

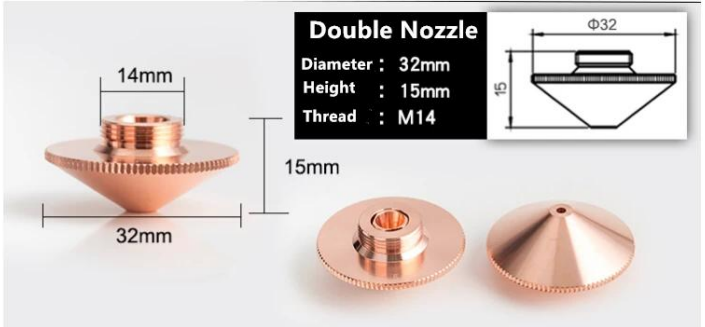
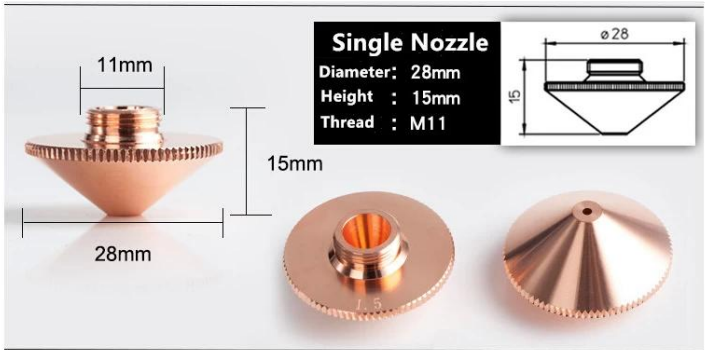
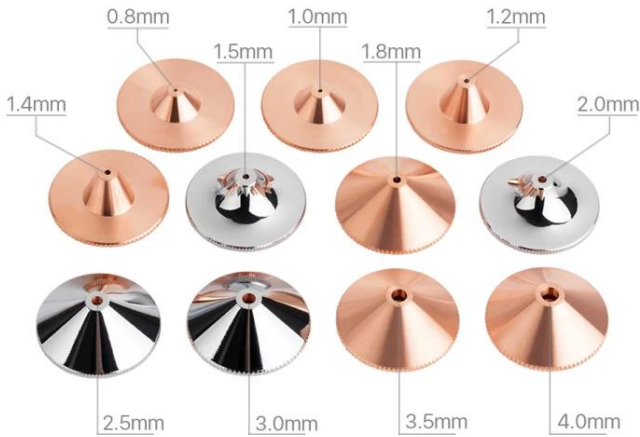

Precitec A

Precitec B

Precitec C

Precitec D

Precitec D



## PRODUCT SPECIFICATIONS

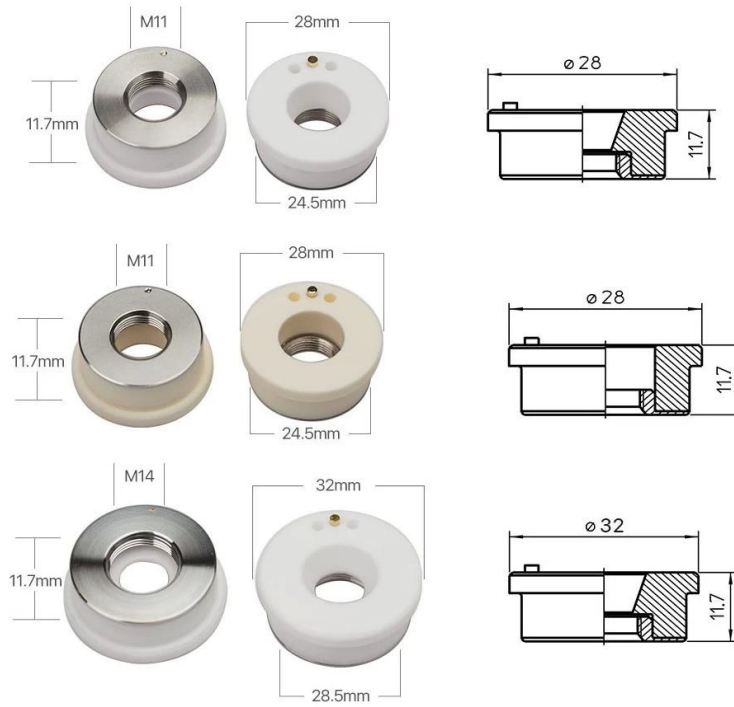

## PACKAGING



## Faserlaserschneidkopfdüse:

Durchmesser (mm)	Höhe (mm)	Dicke (mm)	Glaser
28.	fünfzehn	Doppelt	1.0 / 1.2 / 1.5 / 2.0 / 2.5 / 3.0 / 3.5 / 4.0 / 4.5 / 5.0
28.	fünfzehn	Einzel	1.0 / 1.2 / 1.5 / 2.0 / 2.5 / 3.0 / 3.5 / 4.0 / 4.5 / 5.0
32.	fünfzehn	Doppelt	1.0 / 1.2 / 1.5 / 2.0 / 2.5 / 3.0 / 3.5 / 4.0 / 4.5 / 5.0
32.	fünfzehn	Einzel	1.0 / 1.2 / 1.5 / 2.0 / 2.5 / 3.0 / 3.5 / 4.0 / 4.5 / 5.0
10.7.	22.2.	Doppelt	1.0 / 1.2 / 1.5 / 2.0 / 2.5 / 3.0 / 3.5 / 4.0
10.7.	22.2.	Einzel	1.0 / 1.2 / 1.5 / 2.0 / 2.5 / 3.0 / 3.5 / 4.0
11.4.	16.	/	0,8 / 1,0 / 1,2 / 1,5 / 2,0 / 2,5
fünfzehn	19.	Doppelt	1.0 / 1.2 / 1.5 / 2.0 / 2.5 / 3.0
fünfzehn	19.	Einzel	0,8 / 1,0 / 1,2 / 1,5 / 1,8 / 2,0 / 2,5 / 3.0

## [Faserlaserschneidendüse Hersteller China](#)

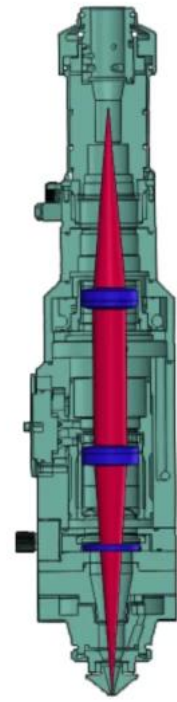
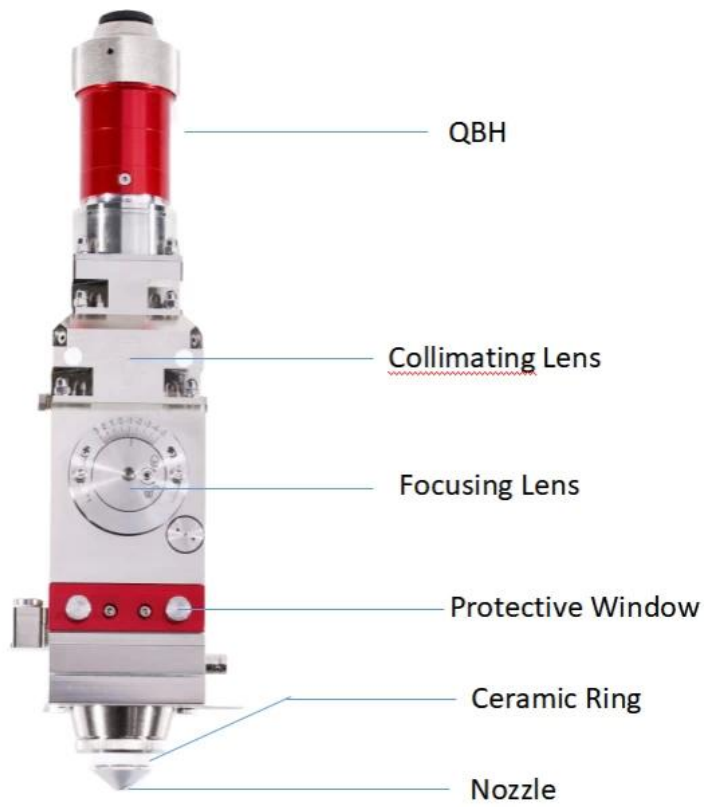

光纤切割头光路示意图  
Figure of Fiber Cutting Head

Fabrik







重要仪器,  
非专业人士勿动。

OptiCentric 300

TRIOPTICS







PerkinElmer Lambda 950---Testing Transmission and Reflectivity



## Zertifikat & Ausstellung.



# CERTIFICATE

## ATTESTATION CERTIFICATE OF MACHINERY AND LOW VOLTAGE DIRECTIVES

Technical file of the company mentioned below has been observed and audit has been completed successfully. 2006/42/EC Machinery Directive and 2014/35/EU Low Voltage Directive have been taken as references for these processes

Company Name : **Camnan HAAS Laser Technology (Suzhou) Co., Ltd.**

Company Address : No 155, West Road Suhong, Suzhou Industrial Park, Suzhou City, Jiangsu , P.R.China

Related Directives and Annex : **Low Voltage Directive 2014/35/EU  
Machinery Directive 2006/42/EC**

Related Standards : **EN ISO 12100:2010; EN 60204-1:2006+A1:2009+AC:2010**

Product Name : **Laser Marking Machine**

Report No and Date : SD-90049717:09.08.2018

Product Brand/Model/Type : LMCH-3W,LMCH-5W,LMCH-10W,LMCH-15W,LMCH-20W,LMCH-25W,  
LMCH-30W,LMCH-50W,LMCH-60W,LMCH-70W,LMCH-100W,  
LMCH-120W,LMCH-150W,LMCH-200W,LMCH-300W,LMCH-500W

Certificate Number : **M.2018.201.N6073**

Initial Assessment Date : 10.08.2018

Registration Date : 13.08.2018

Reissue Date/No :

Expiry Date : **12.08.2023**

*Signature*  
UDM International Certification  
Auditing Training Centre Industry  
and Trade Inc. Co.



The validity of the certificate can be checked through [www.udem.com.tr](http://www.udem.com.tr). The CE mark shown on the right can only be used under the responsibility of the manufacturer with the completion of EC Declaration of Conformity for all the relevant Directives. This certificate remains the property of UDEM International Certification Auditing Training Centre Industry and Trade Inc. Co. to whom it must be returned upon request. The above named firm must keep a copy of this certificate for 15 years from the registration of certificate. This certificate only covers the product(s) stated above and UDEM must be notified in case of any changes on the product(s)  
Address: Mulkikent Mahallesi 2073 Sokak (Eski 93 Sokak) No:10 Çankaya - Ankara - TÜRKİYE  
Phone: +90 0312 443 03 90 Fax: +90 0312 443 03 70  
E-mail: [info@udemtd.com.tr](mailto:info@udemtd.com.tr) [www.udem.com.tr](http://www.udem.com.tr)



## Certificate of Approval

Certificate No.: 10119Q12565ROM

Awarded to

**Carman Haas Laser Technology(SuZhou)  
Co., Ltd.**

Organization Code Certificate No. / Unified Social Credit Code:91320594M1MF4EP56  
Add.:No.155, West Road Suhong, Suzhou Industrial Park, Suzhou City, Jiangsu Province, P.R. China. 215000

Beijing ZhongLian TianRun Certification Center (ZLTR) certify that the  
Quality Management System of the above organization has been assessed and found to be  
in accordance with the requirements of the standard:  
**GB/T19001-2016 / ISO9001:2015**

### SCOPE OF CERTIFICATION/REGISTRATION

The Research and Development and Production of Optics Lenses (Except the limits of national laws and regulations.)

This certificate is made valid when used with certification scopes and the requirements of applicable laws and regulations. These requirements include, but are not limited to, administrative permits, scopes of qualifications, and CCC requirements.

Subject to operation conditions in requirements conformity with Quality Management System,

This Certificate is valid for a period of three years only,  
Date from: Mar 13th,2019 To: Mar 12th,2022

The effectiveness of this Certificate shall be Validated by periodic surveillance audit  
of ZLTR for maintenance.

Information of this certificate can be found on the official website of Beijing Zhonglian Tianrun  
Certification center (<http://www.zltr.com.cn>)



Beijing Zhongliantianrun Certification Center

Room2603, 22nd Floor, 2nd Unit, Block 1, No.4 Yard, Qiyang Road, Chaoyang District, Beijing, P.R. China 100102

Information of this certificate can be found on the official website of Certification and Accreditation Administration of the People's Republic of China (<http://www.cnca.gov.cn>)

ISO 9001

ISO 9001



## Packliste



**Rücknahmegarantie:**

Sollte zurücksendet sein:

Schritt 1) Kontaktieren Sie uns mit dieser Website-E-Mail.

Schritt 2) Sorgen Sie so viel Details wie möglich über das Problem, das Sie haben.

Schritt 3) Berechtigung zur Rücksendung des Artikels wird ausgegeben.

Schritt 4) Geben Sie den Artikel für den vereinbarten Ersatz oder die Erstattung zurück.

### **Logistik:**

(1) Für die Anordnung der Laseroptik kann optional mit DHL, USV, FedEx, TNT, EMS usw. optional sein

(2) Für die Auftragslieferung der Lasermaschinen kann optional mit Begriffen von EXROD, FOB, CNF, CIF durch Luft oder auf dem Seeweg auf Basis des Forwar-Randes des Käufers oder von unserem Käufer sein.

## FAQ

F1. Alle Sie ein Hersteller?

A1: Ja, wir sind professioneller und erfahrener Hersteller mit eigenen Formen und Produktionslinien.

F2. Wie über die Qualität der Produkte?

A2: Unsere Techniker und QC-Teams testen die Produkte nach einem von einer Alterungslinie, professionellen Geräten und Instrumenten, um die Qualität für alle Produkte zu gewährleisten.

F3. Wie über den Preis?

A3: Wir sind Hersteller und bieten unseren Kunden immer die wettbewerbsfähigsten Preise an.

F4. Wiehen Sie eine Bestellung auf?

A4: Kontakt mit dem Online-Service oder per E-Mail direkt an uns gesendet, wir antworten Ihnen bald mit Produktpreis, Spezifikationen, Verpackungen usw.. Dankeschön.

Q5. MAY Ich sende Material, um die Markierungsleistung zu testen?

A5: Ja! Gerne können Sie Material senden, um unsere überlegene Qualität und Ihren Service zu testen.

Q6. can Ich besuche deine Fabrik?

A6: Ja, willkommen, unsere Fabrik zu Ihrer günstigen Zeit zu besuchen.

F7. Wie kann ich OEM- oder ODM-Bestellungen machen?

A7: Wir haben unterschiedliche Druckverarbeitung für verschiedene OEM / ODM-ORD. Bitte kontaktieren Sie uns mit einem Online-Service oder senden Sie uns E-Mail direkt an uns.

Q8. Wie soll ich für meine Bestellungen bezahlen?

A8: Sie können von t / t zahlen, um für qualifizierte Bank und MOQ für jede Bestellung erforderlich zu sein.