



Produktbeschreibung:

Carmanhaas. [Laser-Schneidkopf-Schutzlinsen-Fensterhersteller](#), liefern Sie YAG / FIBER / 1064NM Schutzfenster für Faserschneidkopf. Wird in verschiedenen Arten von Faserlaserschneidkopf verwendet, Senden und Fokussieren des Strahls von der Faser, um den Zweck des Schneidens des Blattes zu erreichen. Bewerben Sie sich auf 500W 1000W 1500W 2000W 4000W 6000W-Laser.



Erfahren Sie mehr: [PRECITEC-Laserschneidkopf-Schutzlaserfenster](#)

Schützendfenster

Durchmesser (mm)	Dicke (mm)	Glaser
21.5.	2.	AR / AR @ 1030-1090nm
24.9.	1.5.	AR / AR @ 1030-1090nm
32.	2.	AR / AR @ 1030-1090nm
38.1.	1.5.	AR / AR @ 1030-1090nm
22.35.	4.	AR / AR @ 1030-1090nm
25.4.	4.	AR / AR @ 1030-1090nm
27.9.	4.	AR / AR @ 1030-1090nm
30.	5.	AR / AR @ 1030-1090nm
32.	5.	AR / AR @ 1030-1090nm
37.	7.	AR / AR @ 1030-1090nm
38.1.	6.35.	AR / AR @ 1030-1090nm

P / n.	Substrat	Dia. (mm)	Et. (mm)	Glaser
W-9.5-1.5.	K9 / FUSCUDED SILAGIA	9.5.	1.5.	AR / AR @1064nm
W-12.7-2.	K9 / FUSCUDED SILAGIA	12.7.	2.	AR / AR @ 1064nm
W-20-3.	K9 / FUSCUDED SILAGIA	20.	3/5.	AR / AR @ 1064nm
W-22.35-4.	K9 / FUSCUDED SILAGIA	22.35.	4.	AR / AR @ 1064nm
W-30-5.	K9 / FUSCUDED SILAGIA	30.	5.	AR / AR @ 1064nm
W-34-3.	K9 / FUSCUDED SILAGIA	34.	3	AR / AR @ 1064nm
W-37-2.	K9 / FUSCUDED SILAGIA	37.	2/7.	AR / AR @ 1064nm
W-50-10.	K9 / fusioniert.Siliciumdioxid	50.	10.	AR / AR @ 1064nm

*** Die oben genannten Listen sind unsere Standardteile und können auch die kundenspezifischen Teile für Sie herstellen.**

Installation Diagram

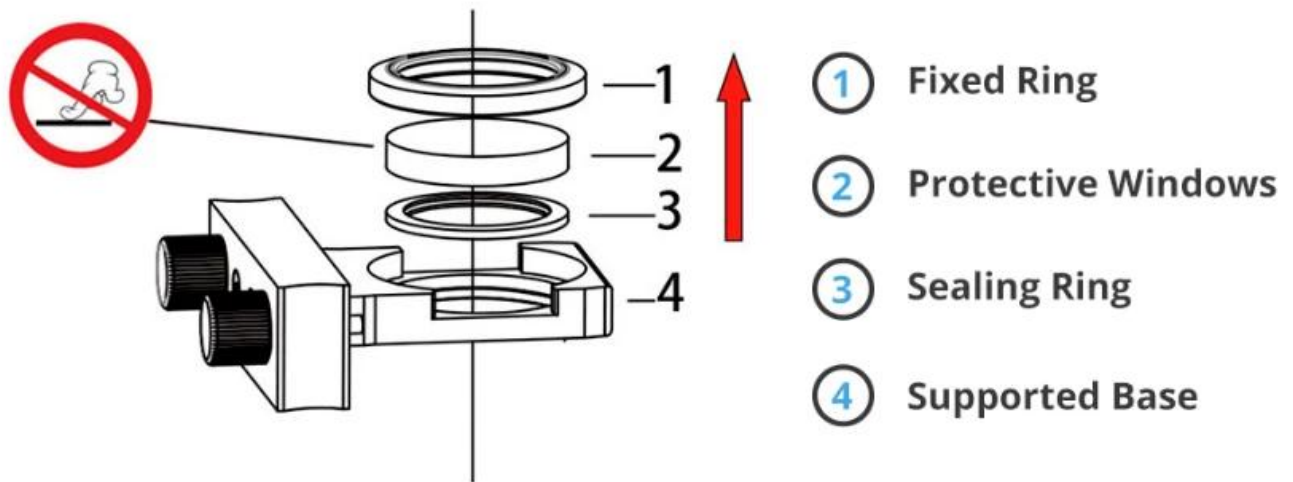

NOTICE: 1—3 Parts Should be taken out in the direction of the arrow, otherwise these parts will be damaged.







重要仪器,
非专业人士勿动。

OptiCentric 300

TRIOPTICS





PerkinElmer Lambda 950---Testing Transmission and Reflectivity







CERTIFICATE

ATTESTATION CERTIFICATE OF MACHINERY AND LOW VOLTAGE DIRECTIVES

Technical file of the company mentioned below has been observed and audit has been completed successfully. 2006/42/EC Machinery Directive and 2014/35/EU Low Voltage Directive have been taken as references for these processes

Company Name : **Camman HAAS Laser Technology (Suzhou) Co., Ltd.**

Company Address : No 155, West Road Suhong, Suzhou Industrial Park, Suzhou City, Jiangsu , P.R.China

Related Directives and Annex : **Low Voltage Directive 2014/35/EU
Machinery Directive 2006/42/EC**

Related Standards : **EN ISO 12100:2010; EN 60204-1:2006+A1:2009+AC:2010**

Product Name : **Laser Marking Machine**

Report No and Date : SD-90049717:09.08.2018

Product Brand/Model/Type : LMCH-3W,LMCH-5W,LMCH-10W,LMCH-15W,LMCH-20W,LMCH-25W,
LMCH-30W,LMCH-50W,LMCH-60W,LMCH-70W,LMCH-100W,
LMCH-120W,LMCH-150W,LMCH-200W,LMCH-300W,LMCH-500W

Certificate Number : **M.2018.201.N6073**

Initial Assessment Date : 10.08.2018

Registration Date : 13.08.2018

Reissue Date/No :

Expiry Date : **12.08.2023**

Signature
UDM International Certification
Auditing Training Centre Industry
and Trade Inc. Co.



The validity of the certificate can be checked through www.udem.com.tr. The CE mark shown on the right can only be used under the responsibility of the manufacturer with the completion of EC Declaration of Conformity for all the relevant Directives. This certificate remains the property of UDEM International Certification Auditing Training Centre Industry and Trade Inc. Co. to whom it must be returned upon request. The above named firm must keep a copy of this certificate for 15 years from the registration of certificate. This certificate only covers the product(s) stated above and UDEM must be noticed in case of any changes on the product(s)
Address: Mulkikent Mahallesi 2073 Sokak (Eski 93 Sokak) No:10 Çankaya - Ankara - TÜRKİYE
Phone: +90 0312 443 03 90 Fax: +90 0312 443 03 70
E-mail: info@udemtd.com.tr www.udem.com.tr



Certificate of Approval

Certificate No.: 10119Q12565ROM

Awarded to

**Carman Haas Laser Technology(SuZhou)
Co., Ltd.**

Organization Code Certificate No. / Unified Social Credit Code:91320594MA1MF4EP56
Add.:No.155, West Road Suhong, Suzhou Industrial Park, Suzhou City, Jiangsu Province, P.R. China. 215000

Beijing ZhongLian TianRun Certification Center (ZLTR) certify that the
Quality Management System of the above organization has been assessed and found to be
in accordance with the requirements of the standard:
GB/T19001-2016 / ISO9001:2015

SCOPE OF CERTIFICATION/REGISTRATION

The Research and Development and Production of Optics Lenses (Except the limits of national laws and regulations.)

This certificate is made valid when used with certification scopes and the requirements of applicable laws and regulations. These requirements include, but are not limited to, administrative permits, scopes of qualifications, and CCC requirements.

Subject to operation conditions in requirements conformity with Quality Management System,

This Certificate is valid for a period of three years only,

Date from: Mar 13th,2019 To: Mar 12th,2022

The effectiveness of this Certificate shall be Validated by periodic surveillance audit of ZLTR for maintenance.

Information of this certificate can be found on the official website of Beijing Zhonglian Tianrun Certification center (<http://www.zltr.com.cn>)



Beijing Zhongliantianrun Certification Center

Room2603, 22nd Floor, 2nd Unit, Block 1, No.4 Yard, Qiyang Road, Chaoyang District, Beijing, P.R. China 100102

Information of this certificate can be found on the official website of Certification and Accreditation Administration of the People's Republic of China (<http://www.cnca.gov.cn>)

ISO 9001

ISO 9001



Packing List



Packaging & Shipping

Packaging 1



Packaging 2



Packaging 3



Shipping 4



Rücknahmegarantie:

Sollte zurückkehren sollen:

Schritt 1) Kontaktieren Sie uns mit dieser Website-E-Mail.

Schritt 2) Sorgen Sie so lange wie möglich über das Problem, das Sie haben.

Schritt 3) Berechtigung zur Rückgabe des Artikels wird ausgestellt.

Schritt 4) Geben Sie den Artikel zum vereinbarten Ersatz oder Rückerstattung zurück.

Logistik:

(1) Für die Anordnung der Laseroptik kann mit DHL, USV, FedEx, TNT, EMS, ETS optional sein

(2) Für die Auftragslieferung der Lasermaschinen kann es optional mit BEGRIFFEN VON EXWORM FOB, CNF, CIF mit Luft oder auf dem Seeweg auf Basis der Spediteure des Käufers oder von unserem Käufer.



FAQ

F1. Alle Sie ein Hersteller?

A1: Ja, wir sind professioneller und erfahrener Hersteller mit eigenen Formen und Produktionslinien.

F2. Wehen Sie nach Qualität der Produkte?

A2: Unsere Techniker und QC-Teams testen die Produkte mit einer Alterungslinie, professionellen Geräten und Instrumenten nach einem anderen, um die Qualität für alle Produkte sicherzustellen.

F3. Wie Über den Preis?

A3: Wir sind Hersteller und bieten unseren Kunden immer die wettbewerbsfähigsten Preise an.

F4. Wehen Sie an, um eine Bestellung aufzugeben?

A4: Kontakt mit dem Online-Service oder E-Mail an uns direkt gesendet, wir antworten Ihnen bald mit Produktpreis, Spezifikationen, Verpackungen usw.. Dankeschön.

F5. MAY Ich sende Material, um die Markierungsleistung zu testen?

A5: Ja! Sie können das Material schicken, um unseren überlegenen Qualität und Service zu testen.

Q6. can Ich besuche deine Fabrik?

A6: Ja, willkommen, unsere Fabrik zu Ihrer günstigen Zeit zu besuchen.

F7. Wie kann ich OEM- oder ODM-Bestellungen machen?

A7: Wir haben unterschiedliche Druckverarbeitung für verschiedene OEM / ODM-Bestellungen. Bitte kontaktieren Sie uns mit einem Online-Service oder senden Sie uns E-Mail direkt an uns.

Q8. Wie soll ich für meine Bestellungen bezahlen?

A8: Sie können von T / T für qualifizierte Bank und MOQ für jede Bestellung verfügbar sein.