

Telecentric F-theta Scan Lenses



1030-1090nm Fiber Laser



532nm Green Laser



355nm UV Laser



□□□□□ □□□□□:

355nm Telecentric F-Theta Scan Lenses

Part Description	FL(mm)	Scan Field (mm)	Max Entrance Pupil (mm)	Working Distance (mm)	Mounting Thread
TSL-355-50-100	100	50x50	7	132	M85x1
TSL-355-50-100	100	50x50	9	135	M85x1
TSL-355-100-170	170	100x100	10	224.6	M85x1
TSL-355-130-250-(15CA)	250	130x130	15	341.8	M85x1
TSL-355-175-305-(15CA)	305	175x175	15	393.8	6-M8

532nm Telecentric F-Theta Scan Lenses

Part Description	FL(mm)	Scan Field (mm)	Max Entrance Pupil (mm)	Working Distance (mm)	Mounting Thread
TSL-532-50-100-(15CA)	100	50x50	15	123.6	M85x1
TSL-532-165-277-(15CA)	277	165x165	15	355.8	M102x1

1064nm/1030-1090nm Telecentric F-Theta Scan Lenses

Part Description	FL(mm)	Scan Field (mm)	Max Entrance Pupil (mm)	Working Distance (mm)	Mounting Thread
TSL-1064-80-130-(14CA)	131.5	80x80	14	158.7	M85x1
TSL-(1030-1090)-45-100-(14CA)	100	45x45	14	137	M85x1
TSL-(1030-1090)-60-120-(15CA)	120	60x60	15	162	M85x1
TSL-(1030-1090)-85-170-(20CA)	170	85x85	20	215.5	M85x1

Optical System Layout

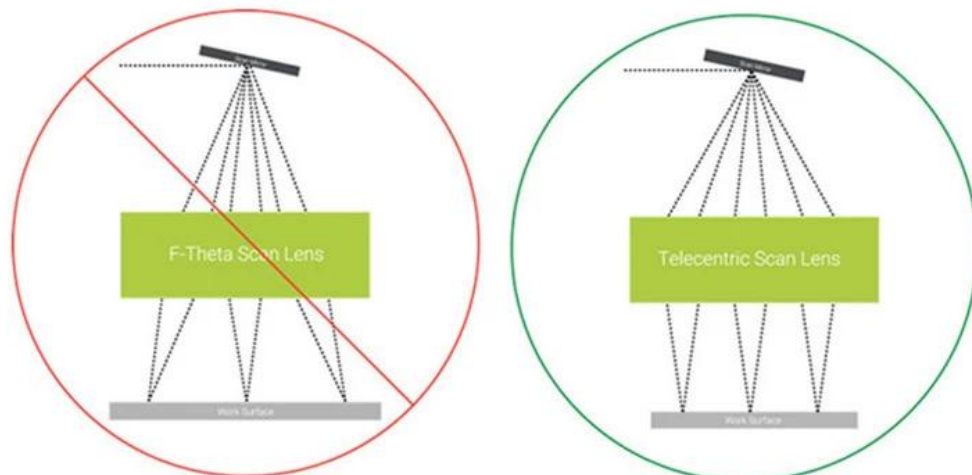
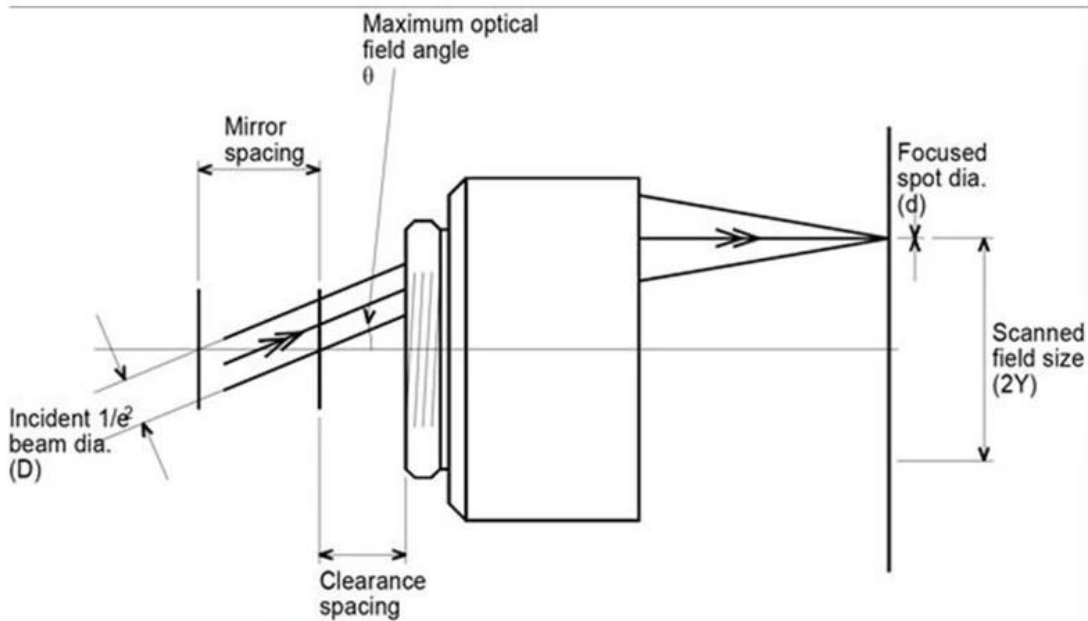

Figure 2: Non-telecentric vs. telecentric f-theta lenses.

Telecentric □□□□ □□□□□□□□ □□□

□□□□□□□□



TRIOPTICS OptiSpheric 2000 AF
---Testing EFL, R, Centering Error, Wedge Angle, BFL, MTF

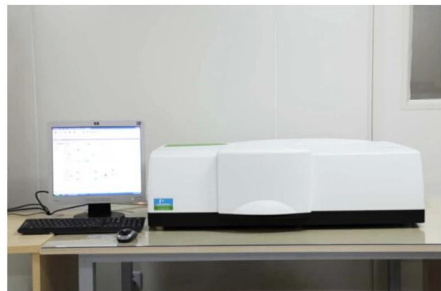

PerkinElmer Lambda 950---Testing Transmission and Reflectivity



Carmanhaas Coating Machine



Packaging & Shipping

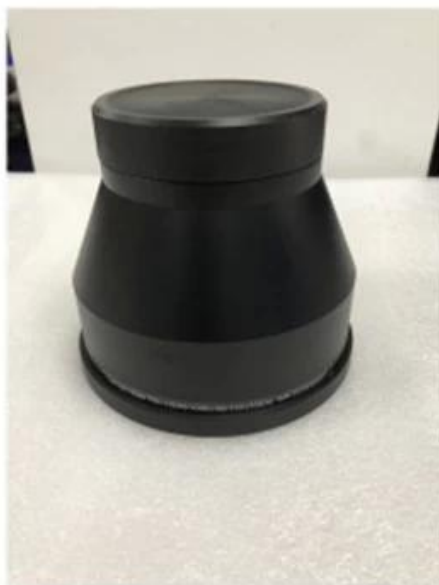

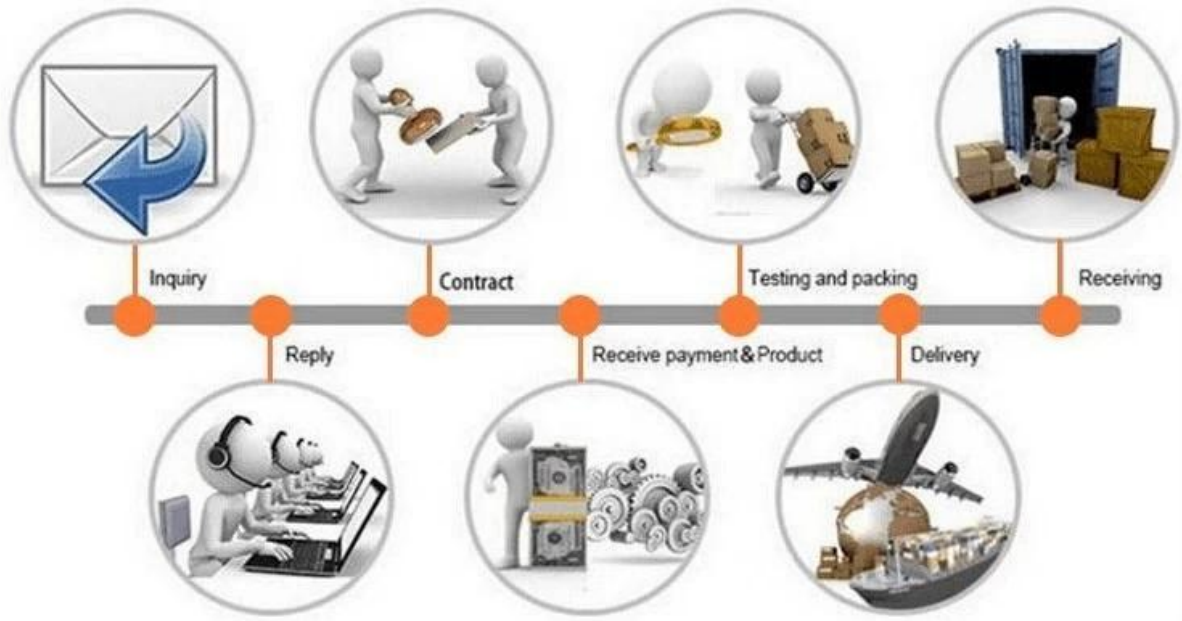

□□□□ □□□□:

請用繁體中文回答以下問題：

- 問題 1) 請說明國際貿易中，出口商與進口商分別承擔哪些風險？
- 問題 2) 國際貿易中，出口商與進口商分別承擔哪些風險？
- 問題 3) 國際貿易中，出口商與進口商分別承擔哪些風險？
- 問題 4) 國際貿易中，出口商與進口商分別承擔哪些風險？

回答：

- (1) 出口商與進口商分別承擔的風險包括：出口商承擔的風險包括：信用風險、匯率風險、運輸風險、FedEx、保險風險、關稅風險
- (2) 出口商與進口商分別承擔的風險包括：EXWork, 關稅風險, CNF, CIF 出口商與進口商分別承擔的風險包括：信用風險、匯率風險、運輸風險、保險風險、關稅風險

國際貿易風險管理

Q1. 出口商與進口商分別承擔哪些風險？

A1: 出口商與進口商分別承擔的風險包括：出口商承擔的風險包括：信用風險、匯率風險、運輸風險、保險風險、關稅風險

進口商承擔的風險包括：信用風險、匯率風險、運輸風險、保險風險、關稅風險 Q2.How

A2: 出口商與進口商分別承擔的風險包括：QC 出口商與進口商分別承擔的風險包括：信用風險、匯率風險、運輸風險、保險風險、關稅風險

出口商與進口商分別承擔的風險包括：信用風險、匯率風險、運輸風險、保險風險、關稅風險 Q3.How

A3: 出口商與進口商分別承擔的風險包括：信用風險、匯率風險、運輸風險、保險風險、關稅風險

Q4.How 出口商與進口商分別承擔哪些風險？

A4: 出口商與進口商分別承擔的風險包括：信用風險、匯率風險、運輸風險、保險風險、關稅風險

Q5.May 出口商與進口商分別承擔哪些風險？

A5: 出口商與進口商分別承擔的風險包括：信用風險、匯率風險、運輸風險、保險風險、關稅風險

Q6. 出口商與進口商分別承擔哪些風險？

A6: 出口商與進口商分別承擔的風險包括：信用風險、匯率風險、運輸風險、保險風險、關稅風險

Q7.How 出口商與進口商分別承擔哪些風險？

A7: 出口商與進口商分別承擔的風險包括：信用風險、匯率風險、運輸風險、保險風險、關稅風險

出口商與進口商分別承擔的風險包括：信用風險、匯率風險、運輸風險、保險風險、關稅風險 8.

