

PRECITEC 28 32:

PRECITEC 28 32 28 32 28 32

28 32:

28 32 (OEM Precitec P0571-1051-00001)

PRECITEC 28 / 24.5 32 12

28 32:

28 32 (OEM Precitec P0571-260-00001)

PRECITEC 28 / 24.5 32 12

28 32:

32 32 (PRECITEC 240 / 109)

PRECITEC 32 / 28.5 32 12

PRECITEC 28 32:

(1) PRECITEC 28 32, PRECITEC 28 32, PRECITEC 28 32

(2) PRECITEC 28 32, PRECITEC 28 32, PRECITEC 28 32, PRECITEC 28 32, PRECITEC 28 32

(3) PRECITEC 28 32, PRECITEC 28 32



Features

Complete specifications, Spot sale.
 Long life time, Not easy to crack, Not easily stained with ash.
 Low Loss Anti-reflectanc, High Efficiency.
 CNC milling and turning, drilling, grinding, tapping, high accuracy and small error.
 100% inspection before shipment, quality assurance.

Product Details

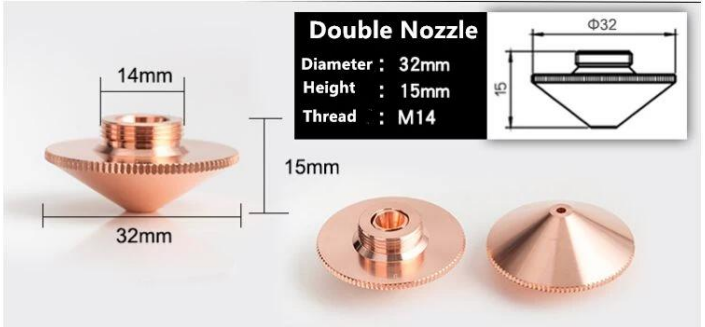
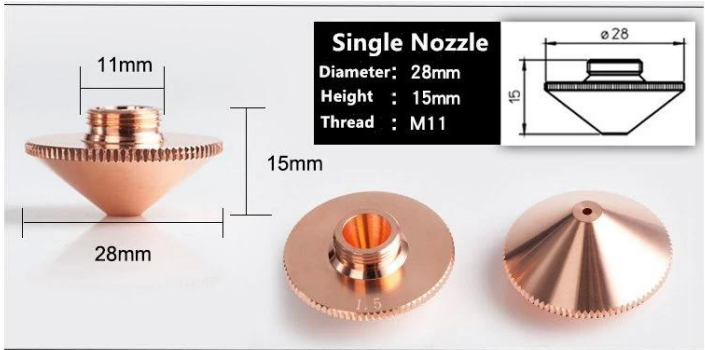



PRODUCT SPECIFICATIONS

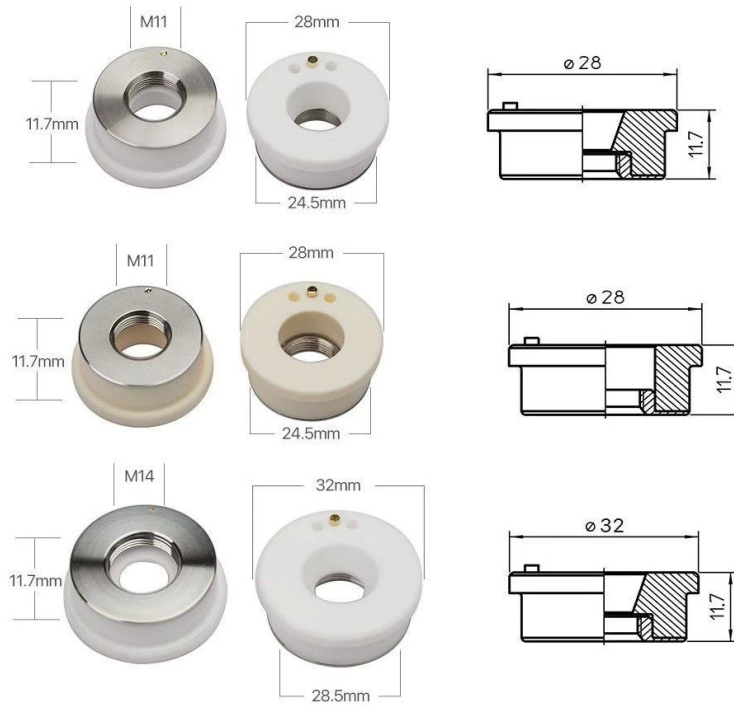

PACKAGING



□□□□ □□□ □□□□ □□ □□□□:

□□□□ (□□□□)	□□□□ (□□□□)	□□□□ (□□□□)	□□□
28	15	□□□□	1,0 / 1,2 / 1,5 / 2,0 / 2,5 / 3,0 / 3,5 / 4,0 / 4,5 / 5,0
28	15	□□	1,0 / 1,2 / 1,5 / 2,0 / 2,5 / 3,0 / 3,5 / 4,0 / 4,5 / 5,0
32	15	□□□□	1,0 / 1,2 / 1,5 / 2,0 / 2,5 / 3,0 / 3,5 / 4,0 / 4,5 / 5,0
32	15	□□	1,0 / 1,2 / 1,5 / 2,0 / 2,5 / 3,0 / 3,5 / 4,0 / 4,5 / 5,0
10.7	22.2	□□□□	1.0 / 1.2 / 1.5 / 2.0 / 2.5 / 3.0 / 3.5 / 4.0
10.7	22.2	□□	1.0 / 1.2 / 1.5 / 2.0 / 2.5 / 3.0 / 3.5 / 4.0
11.4	16	/	0.8 / 1.0 / 1.2 / 1.5 / 2.0 / 2.5
15	19	□□□□	1.0 / 1.2 / 1.5 / 2.0 / 2.5 / 3.0
15	19	□□	0,8 / 1,0 / 1,2 / 1,5 / 1,8 / 2,0 / 2,5 / 3,0

□□□□□□ □□□□ □□□□ □□□□ □□□

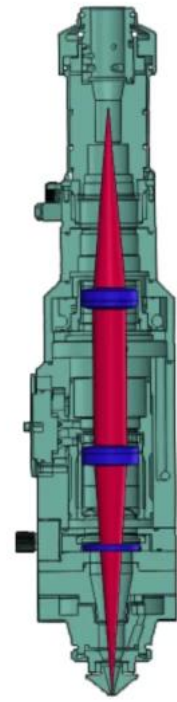
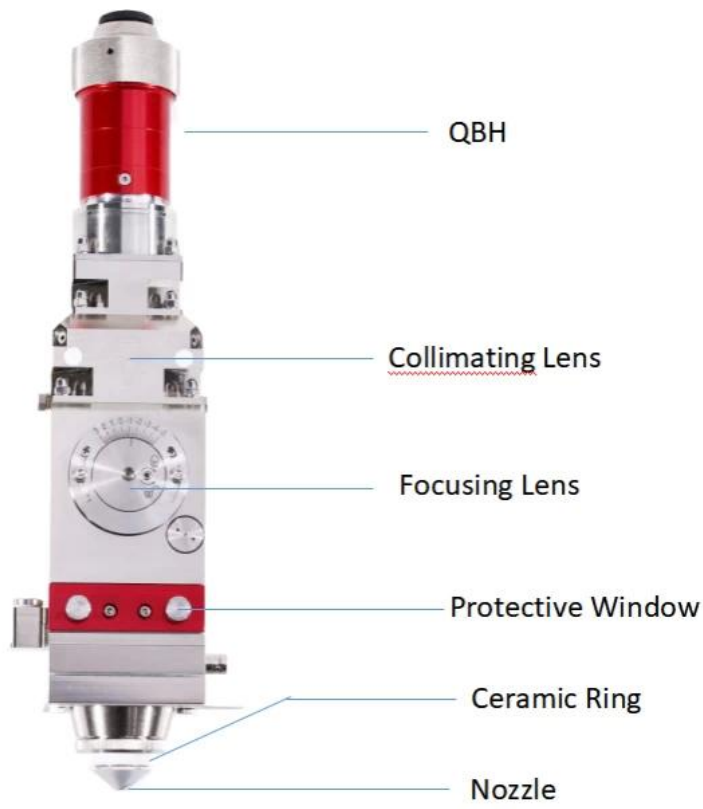

光纤切割头光路示意图
Figure of Fiber Cutting Head





TRIOPTICS OptiSpheric 2000 AF
---Testing EFL, R, Centering Error, Wedge Angle, BFL, MTF



PerkinElmer Lambda 950---Testing Transmission and Reflectivity



Carmanhaas Coating Machine



Packaging & Shipping

Packaging 1



Packaging 2



Packaging 3



Shipping 4





□□□□ □□□:

□□□□□ □□□□:

- 000 1) 00 00000000 0000 00 0000 000000 000000
- 000 2) 0000 00 0000000 00 0000 00, 00000 00000 0000 00000 00000 00 00000 00000000 0000000 000000
- 000 3) 00000 00000 00000 00 0000 00000000000 00000 00000 00000000
- 000 4) 00000 0000 00000000000000 00 000000000 00 0000 00000 00000 000000

000:

- (1) 00000 00000000000 000000 0000000000 00 0000, 0000000000 00000000, 00000000, FedEx, 00000000, 0000000 0000 00 0000 00000 00 00000 00
- (2) 00000 00000 0000000 0000000000 00 0000, EXWork, 000000, CNF, 00000000 00000 0000000 00 00 00000 00000000 00000000 0000000 forwar ders 00 0000000 00000 00 00 0000 0000000000 00 00000 0000

00000000 00000000

Q1 00 00 0000000000 000?

A1: 000, 00 00000 0000 00 00 00 000000 00 000000000 00000000 00 0000 0000000 00 0000000 00000000 000000 0000000000 00000

0000000000 00 0000000000 00 00000 0000 Q2.How

A2: 000000 0000000000000 00 QC 0000000 0000 0000000000 00 0000 0000000000 0000000000 00000 00 0000 00000 0000000 00000, 000000000 000000000 00 000000000 00 0000000 00000 00-00 00000 00000000000 00 000000000 00000 00000

00000 00 00000 0000 Q3.How

A3: 00 00 00000000000 0000 00 0000000 000000 0000000000 00 00000 00000 00000000000000000 00000000 00 000000 00000 00000

Q4.How 00 00000 0000 00 000?

A4: 00000000 00000 00 0000 00000000, 00 00000 00000 00000 00000, 00 00000 00 00 00000000 00 00000, 00000000000000, 00000000 0000 00 0000 00000 00000000000

Q5.May 0000 00000000000 0000000000 00 000000000 00000 00 0000 000000000 0000 00000 0000?

A5: 000! 000000 0000000 0000000000 00 00000 00 000000000 00000 00 0000 000000000 000000 00 0000 00000 00000000 0000

Q6. 0000 00000 000000000 00 00000 00 00000 000?

A6: 000, 00000 000000000000 0000 00 0000000 000000000 00 00000 00000 00 0000 00000 00000000 0000

Q7.How 0000 OEM 00 ODM 00000 00 00000 000?

A7: 00 0000 0000 00000000 000000000000 00 0000 000000000 OEM / ODM ord 0000000000 0000000 00000000 00000 00 0000 00000 0000000 00000 00 00000 00000 00000 00000000

00000000 8 00000 00000 00000000 00 00000000 00000 00000 000000?

A8: 00 00 / 00 00000000 00000000 00 00000 0000 0000000000 00000 00 0000 00000000 000000 00000 00 MOQ 00 0000 00000000 0000000