

Descrizione del prodotto

Carmanhaas. **Porcellana Fabbrica degli ingrossanti della saldatura del laser** Sistema di saldatura dello scanner, integra funzioni come sorgente laser, testa di saldatura a scansione, controllo del fascio, posizionamento visivo, sistema di sicurezza, sistema di raffreddamento, otturatore, ecc., Ha un alto grado di integrazione. Il modulo Galvanometer utilizzato nel sistema ha un'elevata precisione e può garantire un piccolo effetto obiettivo termico durante l'elaborazione. Le prestazioni di dissipazione del calore sono pienamente considerate nel design e il fenomeno della deriva termica focale è ulteriormente soppressa. Il design della struttura completamente sigillato può garantire lavori stabili a lungo termine in ambienti difficili.

Il sistema di controllo appositamente progettato può soddisfare le esigenze dei clienti in diversi campi. Il sistema di controllo è altamente integrato e dotato di un sistema di sicurezza speciale, rendendolo più sicuro, più conveniente e affidabile per i clienti da utilizzare.

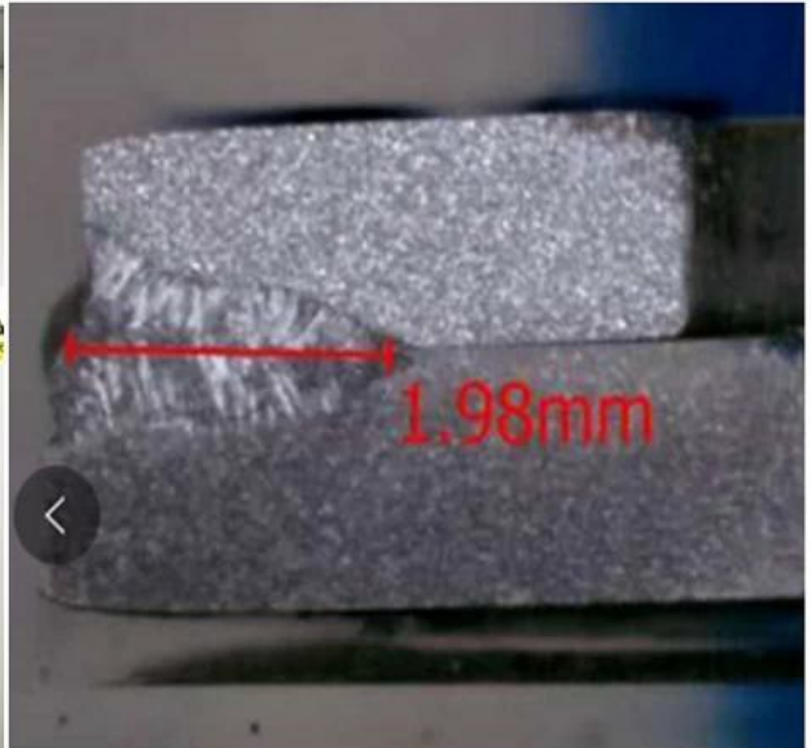

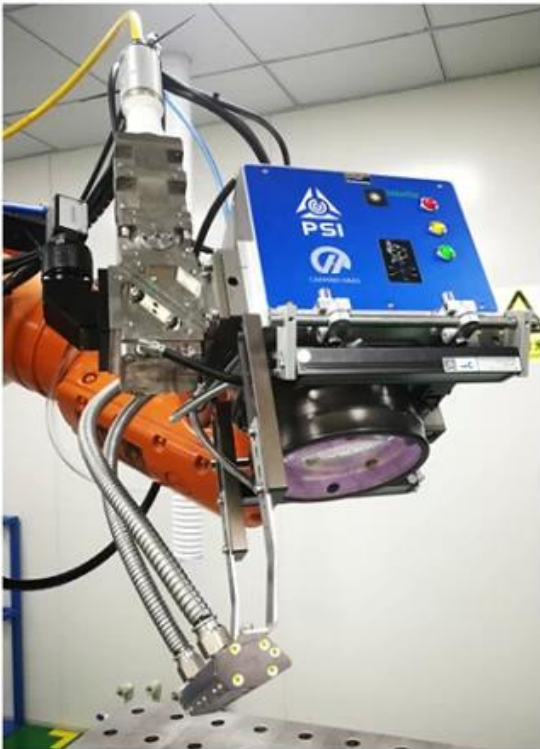
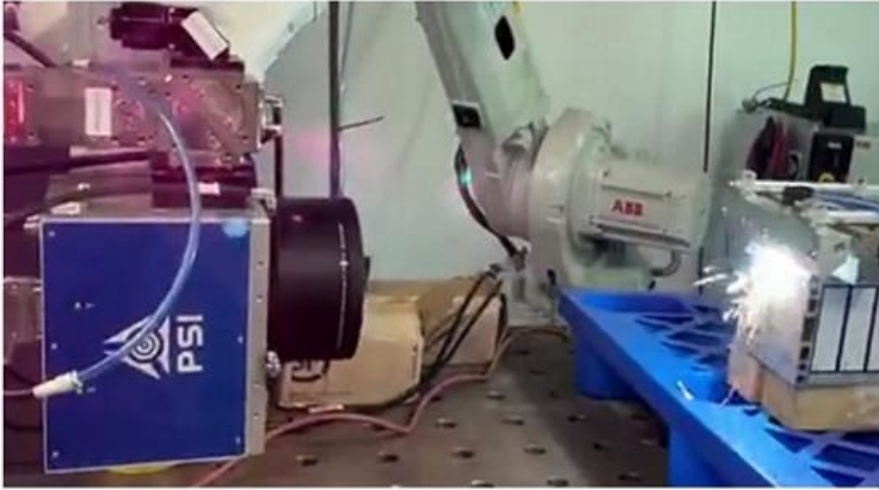

Funzione Swing:

Swing function

Simple pendulum $8\infty 0$

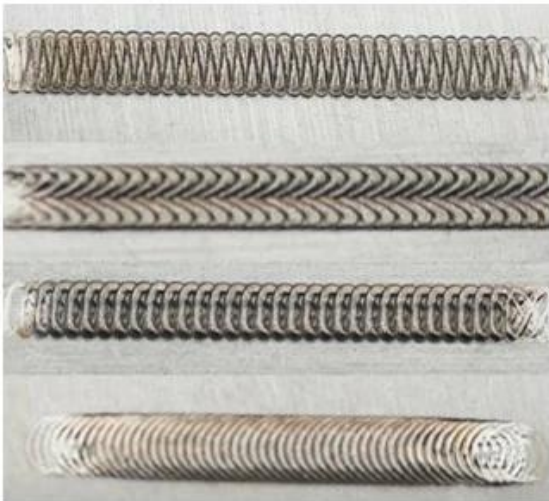

Power rises slowly

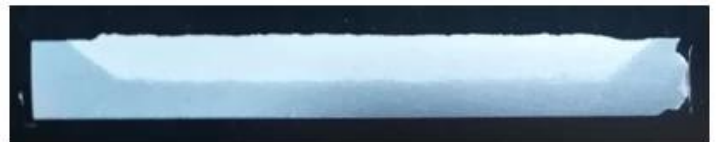

Coltello ad aria ad alte prestazioni:

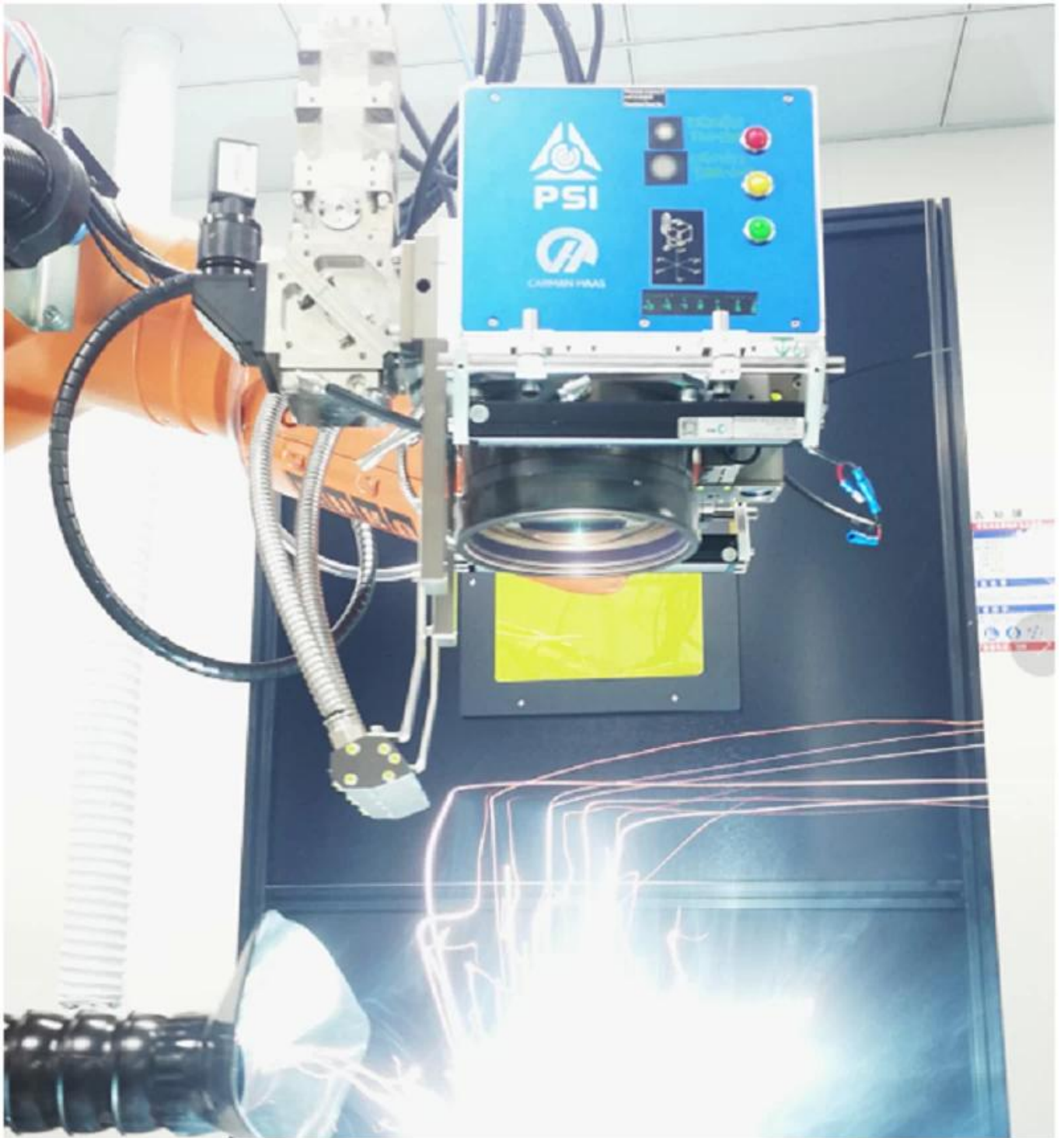

Coerenza della qualità della saldatura:

X,Y(0, 0)

X,Y(90,90)

X,Y(-90,90)

X,Y(-90,-90)

X,Y(-90,90)



Parametro tecnico:

1. lunghezza d'onda: 1030 ~ 1090nm;
2. Potenza laser: laser multimodale 6000W;
3. Potenza laser: laser a modalità singola 2500W
4. Lente collimata FL: FC = 200mm;
5. F-θ Lente di scansione FL: F = 400mm;
6. Lente CCD coassiale: f = 50mm, fotocamera max 1/2 ", connettore C;
7. Intervallo di focus: ± 3mm Collimating Lens Moving;
8. Connettore QBH;
9. Rilevamento dell'alimentazione opzionale: tasso di campionamento 0,5%, frequenza di rilevamento 100Hz;
10. Coltello ad aria (opzionale);
11. Sistema di sicurezza (opzionale);
12. Indicatore di messa a fuoco (opzionale);
13. Sistema di raffreddamento ad aria (opzionale);
14. Sistema di controllo XY2-100;
15. Peso lordo: 18 kg.

[Fornitore di saldatura a testa di scansione Galvo China](#)





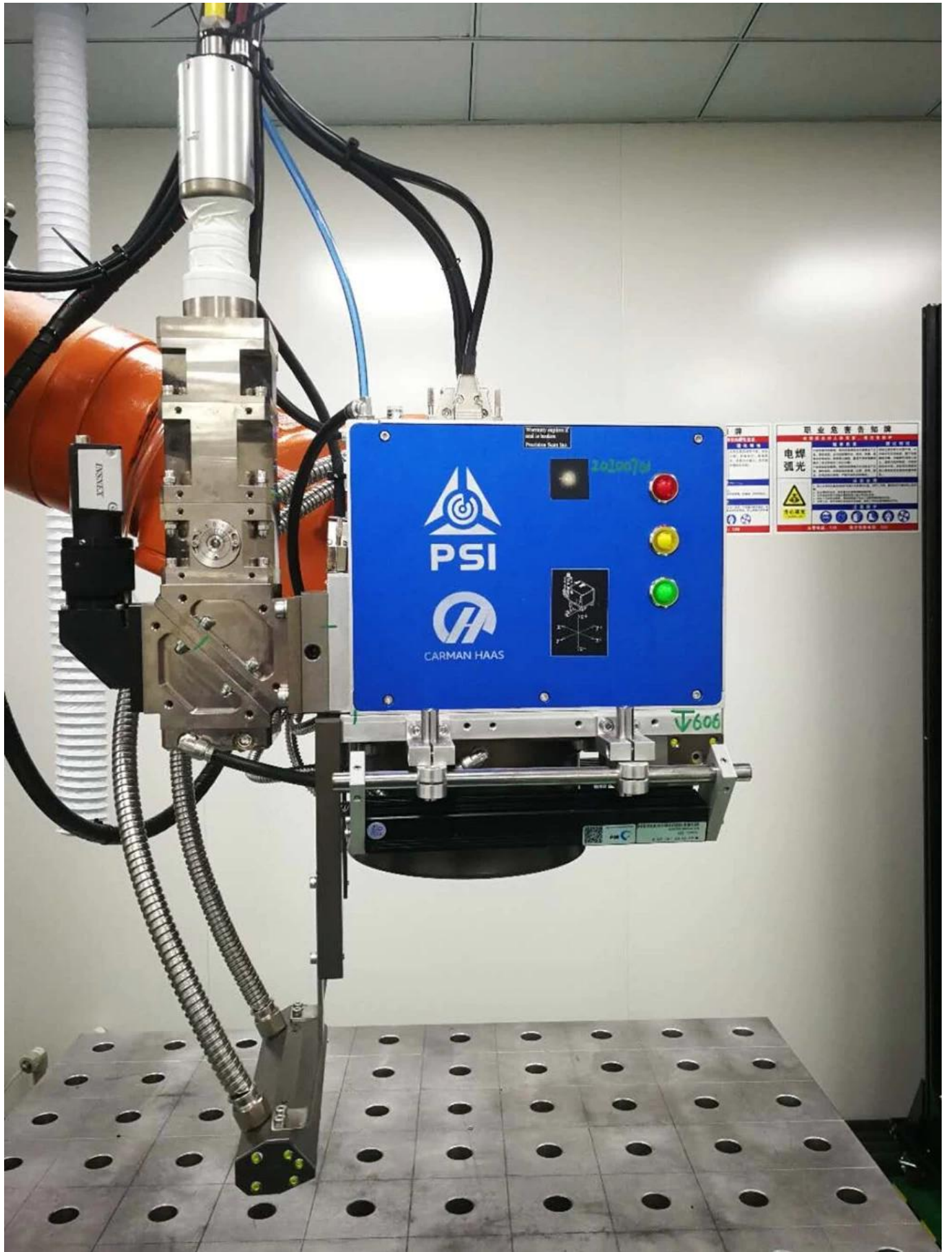

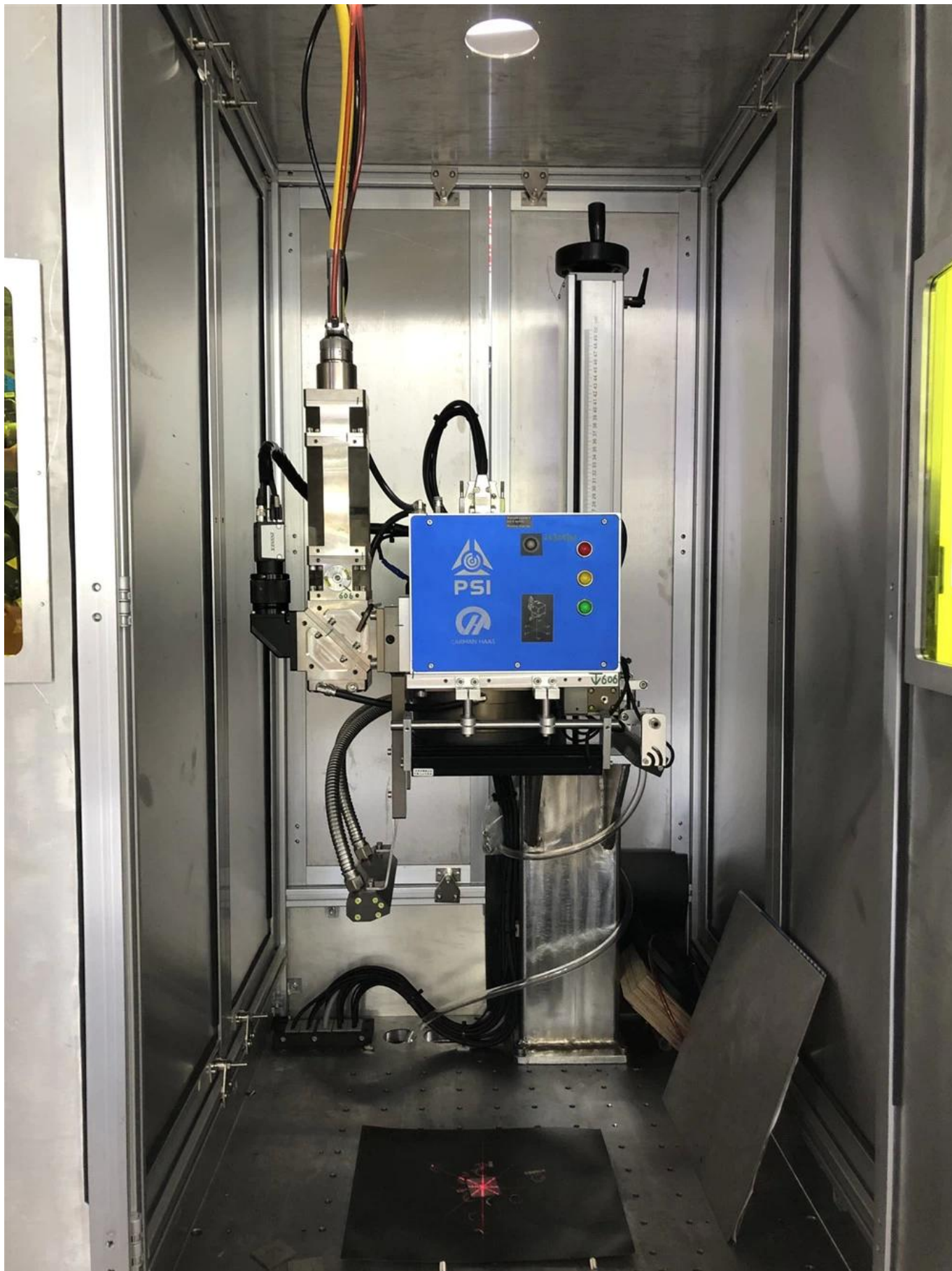

Dimensioni meccaniche (mm):

Vista principale:

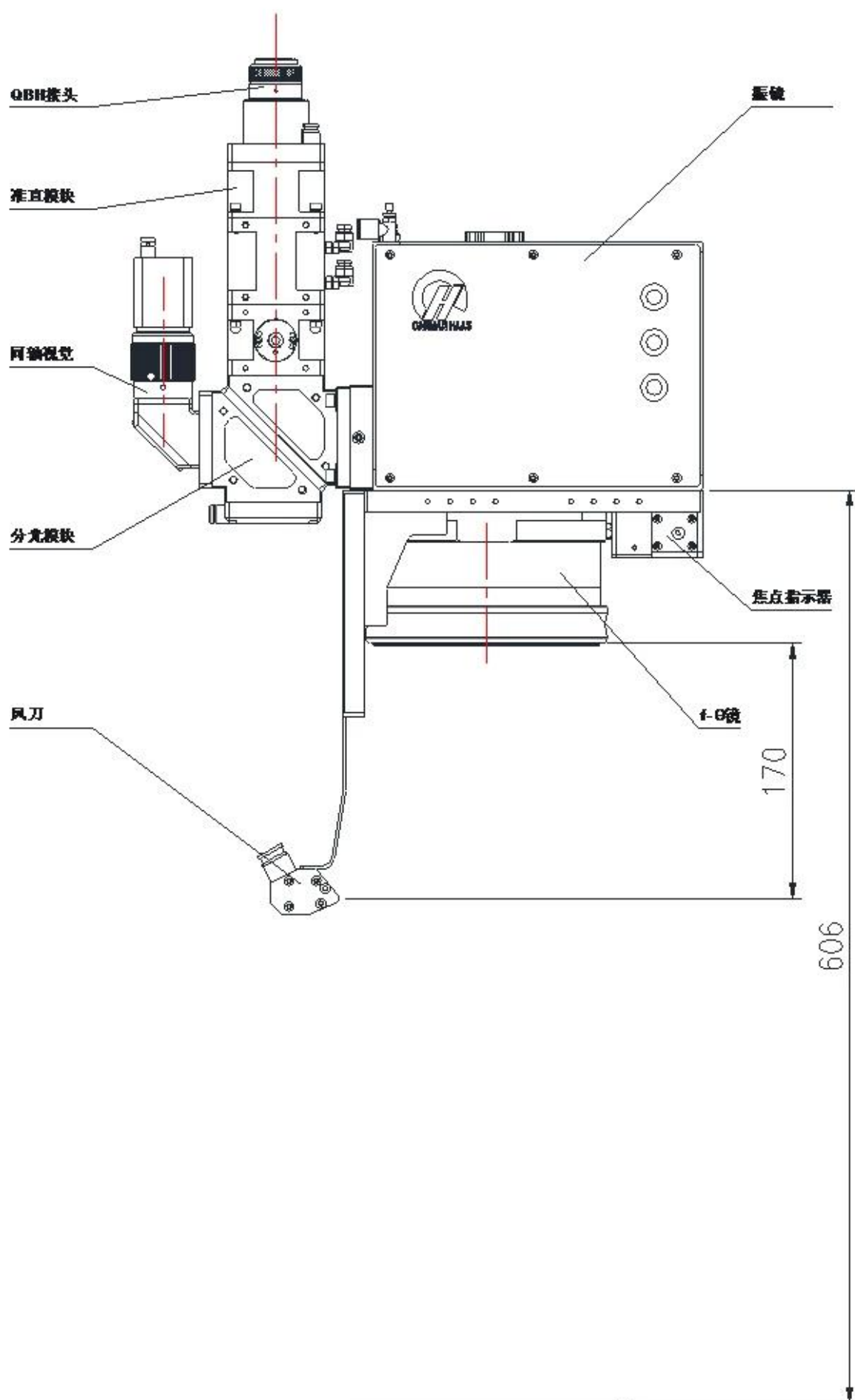

Vista a sinistra:

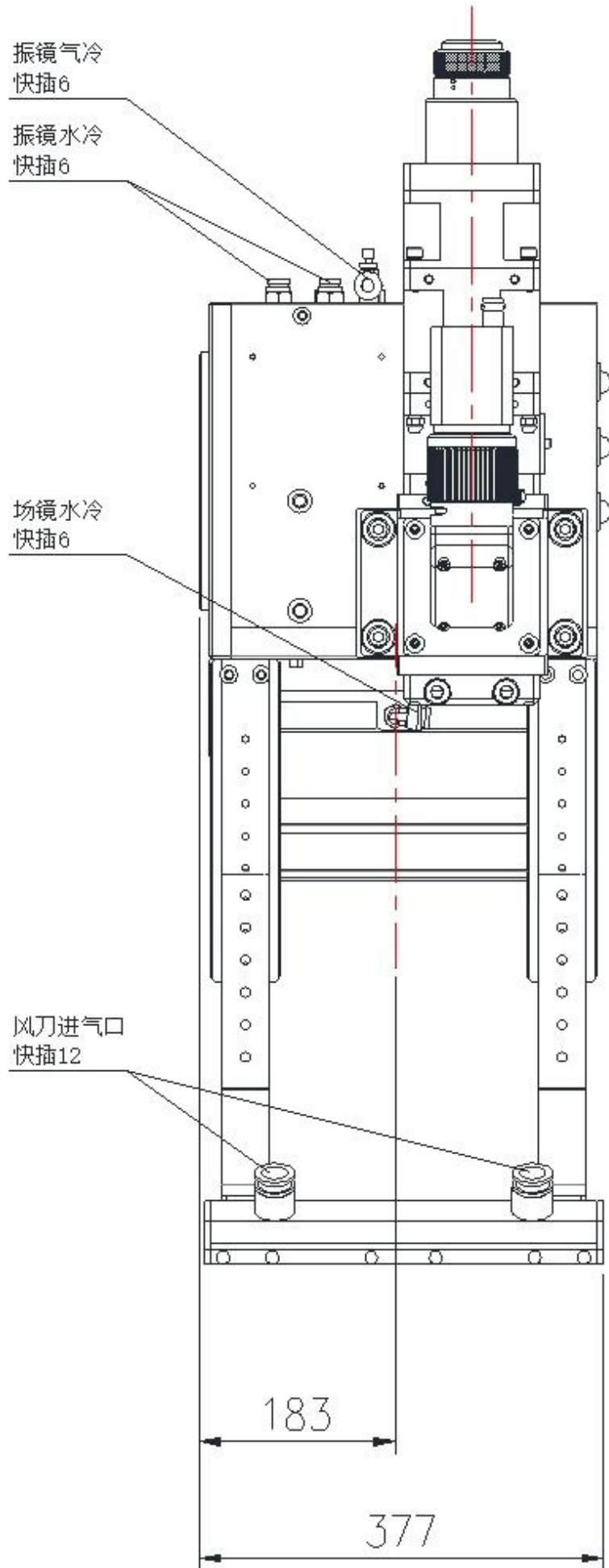

Connettore tra Galvo e lente di scansione:

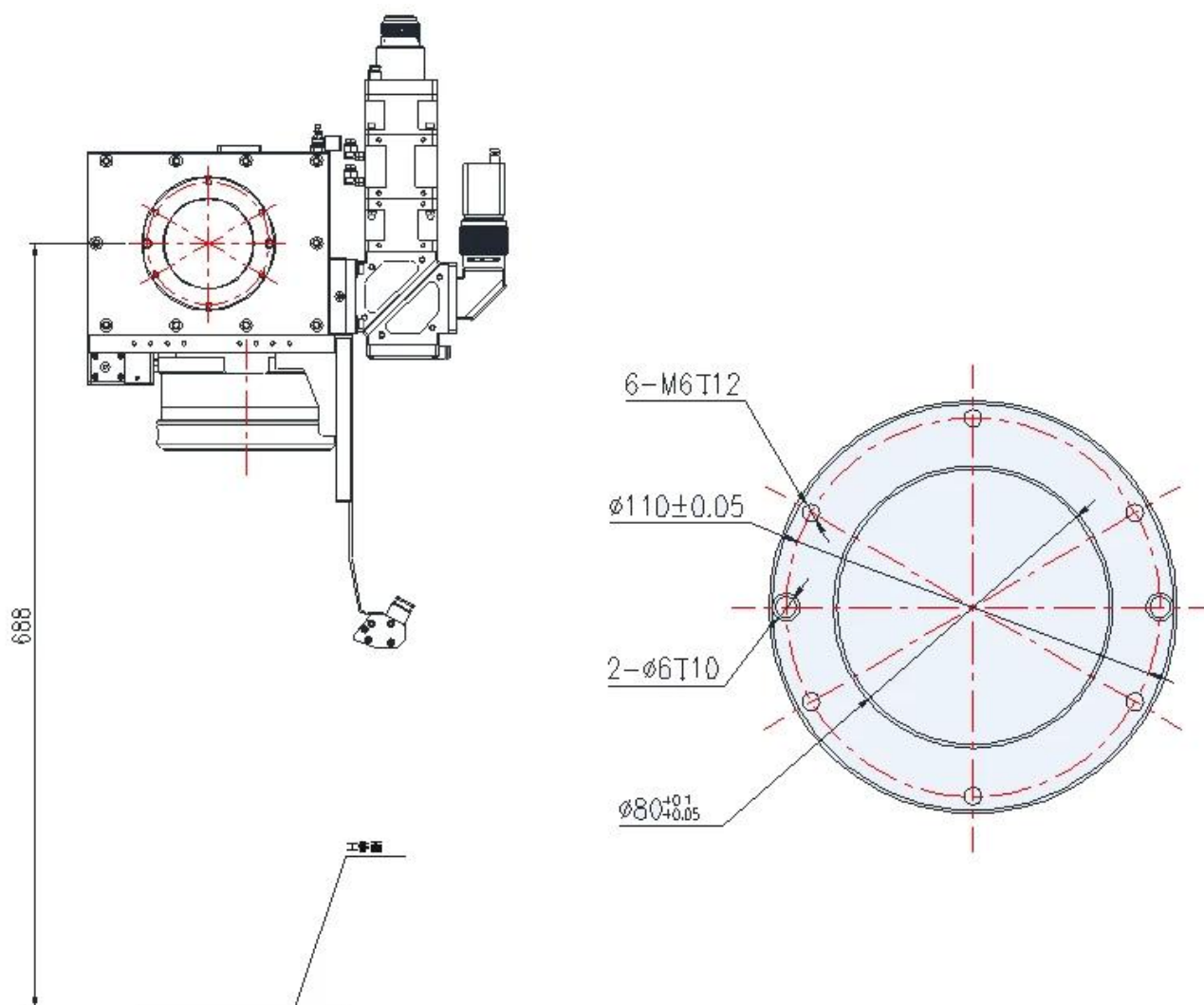

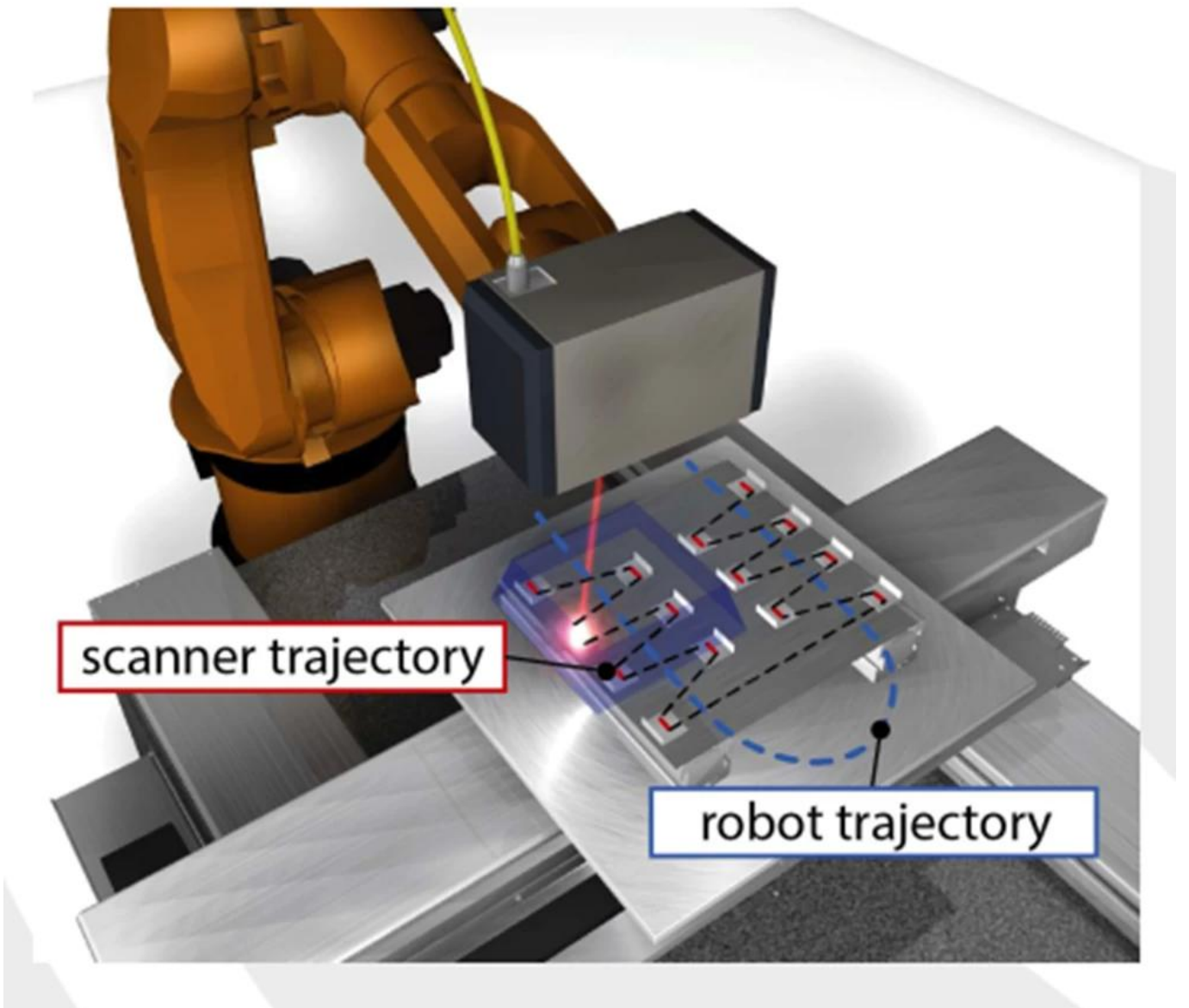







重要仪器,
非专业人士勿动。

OptiCentric 300

TRIOPTICS





PerkinElmer Lambda 950---Testing Transmission and Reflectivity



Certificato e mostra



CERTIFICATE

ATTESTATION CERTIFICATE OF MACHINERY AND LOW VOLTAGE DIRECTIVES

Technical file of the company mentioned below has been observed and audit has been completed successfully. 2006/42/EC Machinery Directive and 2014/ 35/EU Low Voltage Directive have been taken as references for these processes

Company Name : **Camman HAAS Laser Technology (Suzhou) Co., Ltd.**

Company Address : No 155, West Road Suhong, Suzhou Industrial Park, Suzhou City, Jiangsu , P.R.China

Related Directives and Annex : **Low Voltage Directive 2014/35/EU
Machinery Directive 2006/42/EC**

Related Standards : **EN ISO 12100:2010; EN 60204-1:2006+A1:2009+AC:2010**

Product Name : **Laser Marking Machine**

Report No and Date : **SD-90049717.09.08.2018**

Product Brand/Model/Type : **LMCH-3W,LMCH-5W,LMCH-10W,LMCH-15W,LMCH-20W,LMCH-25W,
LMCH-30W,LMCH-50W,LMCH-60W,LMCH-70W,LMCH-100W,
LMCH-120W,LMCH-150W,LMCH-200W,LMCH-300W,LMCH-500W**

Certificate Number : **M.2018.201.N6073**

Initial Assessment Date : **10.08.2018**

Registration Date : **13.08.2018**

Reissue Date/No :

Expiry Date : **12.08.2023**

Signature
UDEM International Certification
Auditing Training Centre Industry
and Trade Inc. Co.

The validity of the certificate can be checked through www.udem.com.tr. The CE mark shown on the right can only be used under the responsibility of the manufacturer with the completion of EC Declaration of Conformity for all the relevant Directives. This certificate remains the property of UDEM International Certification Auditing Training Centre Industry and Trade Inc. Co. to whom it must be returned upon request. The above-mentioned firm must keep a copy of this certificate for 15 years from the registration of certificate. This certificate only covers the product(s) stated above and UDEM must be notified in case of any changes on the product(s).
Address: Mithakere Mahallesi 2073 Sokak (Eski 93 Sokak) No:10 Çankaya - Ankara - TÜRKİYE
Phone: +90 0312 443 03 90 Fax: +90 0312 443 03 76
E-mail: info@udemtd.com.tr www.udem.com.tr



Certificate of Approval

Certificate No.: 10119Q12565ROM

Awarded to

**Carman Haas Laser Technology(SuZhou)
Co., Ltd.**

Organization Code Certificate No. / Unified Social Credit Code:91320594MA1MF4EP56
Add.:No.155, West Road Suhong, Suzhou Industrial Park, Suzhou City, Jiangsu Province, P.R. China. 215000

Beijing ZhongLianTianRun Certification Center (ZLTR) certify that the
Quality Management System of the above organization has been assessed and found to be
in accordance with the requirements of the standard:
GB/T19001-2016 / ISO9001:2015

SCOPE OF CERTIFICATION/REGISTRATION

The Research and Development and Production of Optics Lenses (Except the limits of national laws and regulations.)

This certificate is made valid when used with certification scopes and the requirements of applicable laws and regulations. These requirements include, but are not limited to, administrative permits, scopes of qualifications, and CCC requirements.

Subject to operation conditions in requirements conformity with Quality Management System.

This Certificate is valid for a period of three years only.

Date from: Mar 13th,2019 To: Mar 12th,2022

The effectiveness of this Certificate shall be Validated by periodic surveillance audit of ZLTR for maintenance.

Information of this certificate can be found on the official website of Beijing Zhonglian Tianrun Certification center (<http://www.zltr.com.cn>)



Beijing Zhongliantianrun Certification Center

Room2003, 22nd Floor, 2nd Unit, Block 1, No.4 Yard, Qiyang Road, Chaoyang District, Beijing, P.R. China 100022

Information of the certificate can be found on the official website of Certification and Accreditation Administration of the People's Republic of China (<http://www.cnca.gov.cn>)

ISO 9001

ISO 9001



ImballaggioElenco



Politica di ritorno:

I rendimenti dovrebbero essere richiesti:

Passaggio 1) Contattaci con questa email del sito web.

Passaggio 2) Fornisci più dettagli possibili sul problema che stai avendo.

Passaggio 3) Autorizzazione per restituire l'articolo verrà emesso.

Passaggio 4) Restituire la voce per la sostituzione o il rimborso concordato.

La logistica:

(1) Per la consegna dell'ottica laser, può essere opzionale con DHL, UPS, FedEx, TNT, EMS, ETS

(2) per Laser macchina ordine Consegna, Can. essere opzionale insieme a Termini di Ex lavoro Fob, cnf, cif Di Aria odi Mare basato Sul acquirente spedizioni nostro.

FAQ

Q1. Un produttore?

A1: Sì, siamo produttori professionali ed esperti con i nostri stampi e linee di produzione.

Q2. Come sulla qualità dei prodotti?

A2: I nostri tecnici e i nostri team di controllo qualità testano i prodotti uno per uno utilizzando la linea di invecchiamento, dispositivi professionali e strumenti per garantire la qualità per tutti i prodotti.

Q3. Come sul prezzo?

A3: Siamo un produttore e offriamo sempre ai nostri clienti i prezzi più competitivi.

Q4. Come effettuare un ordine?

A4: contatto con il servizio online, o inviato un'e-mail direttamente a noi, ti risponderemo con il prezzo del prodotto, le specifiche, l'imballaggio ecc. Presto. Grazie.

Q5. Bay I Invio materiale per testare le prestazioni di marcatura?

A5: Sì! Siete invitati a inviare materiale per testare la nostra qualità e servizio di qualità superiore.

Q6. Can Io visito la tua fabbrica?

A6: Sì, benvenuto a visitare la nostra fabbrica al tuo tempo conveniente.

Q7. Come posso fare ordini OEM o ODM?

A7: abbiamo diverse elaborazioni di stampa per diversi OEM / ODM ORDers. Vi preghiamo di contattarci con il servizio online o invia direttamente email direttamente.

Q8. Come dovrei pagare per i miei ordini?

A8: è possibile pagare con T / T sarebbe disponibile per Bank qualificato e MOQ richiesto per ogni ordine.