

□□ □□ :

Carmanhaas □□ □□ 2D □□□ □□□ □□□, 3D □□□ □□□ □□□, □□□, □□□□ □□□ □□□ □□ □□□ □□ □□□ □□□□□.

□□ Carmanhaas (**355** □□ □□□□ □□) □□ (A □□□) □ □□ □□□□ □□□□ □□□ □□□ □□ □□, □□□ □□, □□□ □□, □□□ □□ □□ □□, 3D □□, □□□ □□, □□□ □□, □□□ □□□ □□□□□□ □□ □□□ □□ □□, 2 □ □□□□ □□.

□□:

1.Aperture : 7mm, 10mm, 12mm, 14mm, 16mm, 20mm, 30mm;

□□□, □□□□ □□ □□□□ □□□ □□ □□□ 2.Good□;

□□□ □□□ □□□□□ □□ □□□□ 3.Highest □□ □□;

□□□ □□ □□ □□□□ □□□ □ 4. □□ □□□ □ □□ □□□ □□;

□□ □□□□□□□□ □□ □□□□ □□□ □□ 5.Wide □□.

PRODUCT DETAILS

HIGH SPEED
GALVO LENS

NO.1

SMALL SIZE, FRIENDLY INTERFACE
IN ORDER TO IMPROVE THE QUALITY OF EXPORT,
USE NEW TECHNOLOGY, NEW CRAFT, IN THE GALVO
LENS SCANNING SYSTEM, GRAPHIC IS GOOD, NO DISTORION ETC...

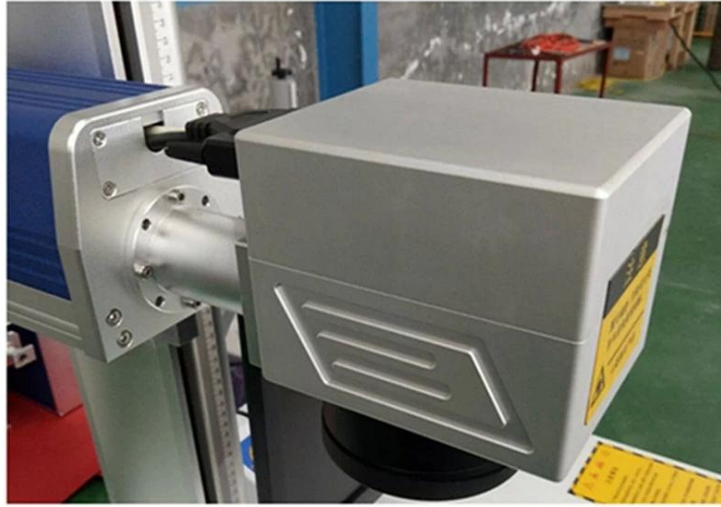

FILED LENS SCANNING SYSTEM TO ADOPT NEW TECHNOLOGY
IMPORTED SCANNING SYSTEM MAKES THE SCANNING SPEED IS
UP TO 7000 MM/S

FILED LENS



CARMAN HAAS



F-theta Lens

Own unique designs with different focal length

Getting a smaller spot size what you demand



Detail Image





UV F-200 UV F-300 UV F-400 UV F-500

UV F-200 UV F-300 UV F-400 UV F-500 :

	ZB2D-10A	ZB2D-10C
UV F-200		
UV F-300 (mm)	10.	10.
UV F-400 UV F-500	± 0.35 mm	± 0.35 mm
UV F-200	<0.5 mrad	<2 mrad
UV F-300	0.15ms	<0.2ms
UV F-400	<0.3ms	<0.4ms
Repeatability	<15 urad	<20 urad
UV F-200	<50 ppm/K	<50 ppm/K
UV F-300	<30 urad/K	<30 urad/K
8mm UV F-200 UV F-300 (30mm UV F-400 UV F-500)	<0.1 mrad	<0.1 mrad
UV F-200	4,000mm / s	8,000mm / s
UV F-300	15m / s	10m / s
UV F-400	± 15 VDC Max.5A	± 15 VDCMax.3A

XY2-100	XY2-100	XY2-100 1000 SPI
± 5V	± 5V	± 10V
355	355	
°C ± 10 ~ 25 °C	°C ± 10 ~ 25 °C	°C ± 10 ~ 25 °C

UV F- (355)

Part Description	FL(mm)	Scan Field (mm)	Max Entrance Pupil (mm)	Working Distance (mm)	Mounting Thread
SL-355-70-100	100	70x70	10	134	M85x1
SL-355-110-170	170	110x110	10	217.6	M85x1
SL-355-150-210	210	150x150	10	249	M85x1
SL-355-175-254	254	175x175	10	306.7	M85x1
SL-355-220-330	330	220x220	10	384.2	M85x1
SL-355-300-420	420	300x300	10	482.3	M85x1
SL-355-360-580	580	360x360	16	660	M85x1
SL-355-520-750	750	520x520	10	824.4	M85x1
SL-355-610-840-(15CA)	840	610x610	15	910	M85x1
SL-355-800-1090-(18CA)	1090	800x800	18	1193	M85x1

(mm) :

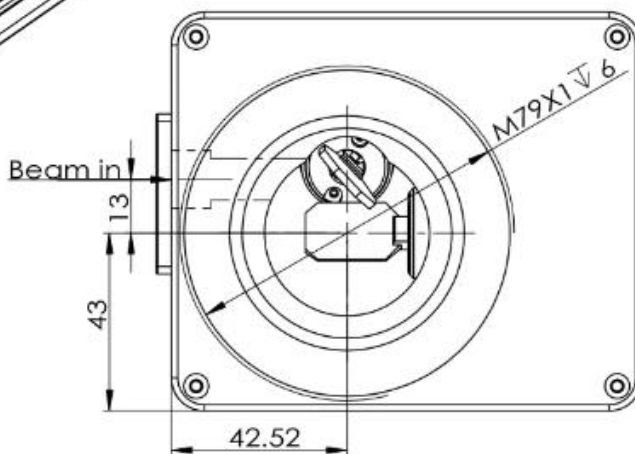
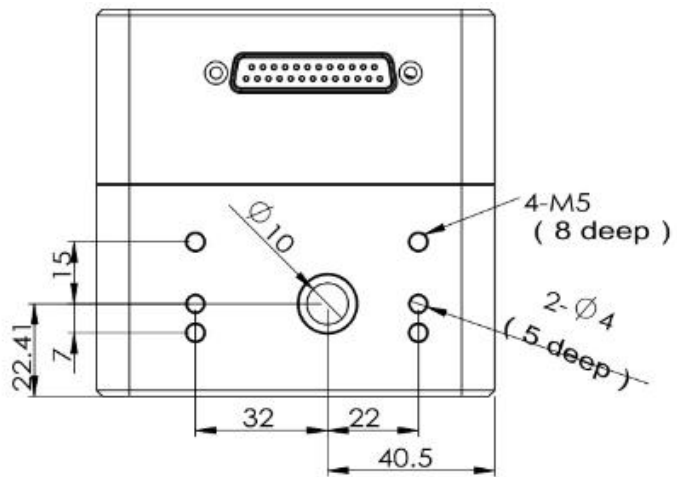
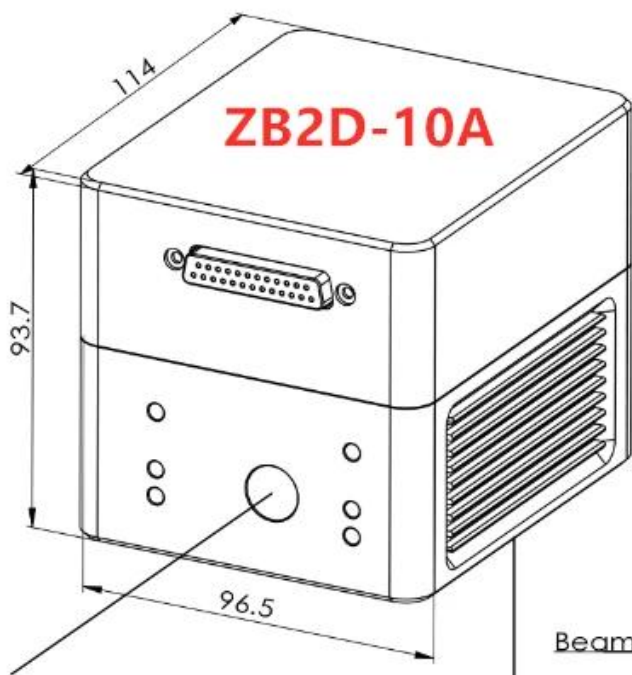

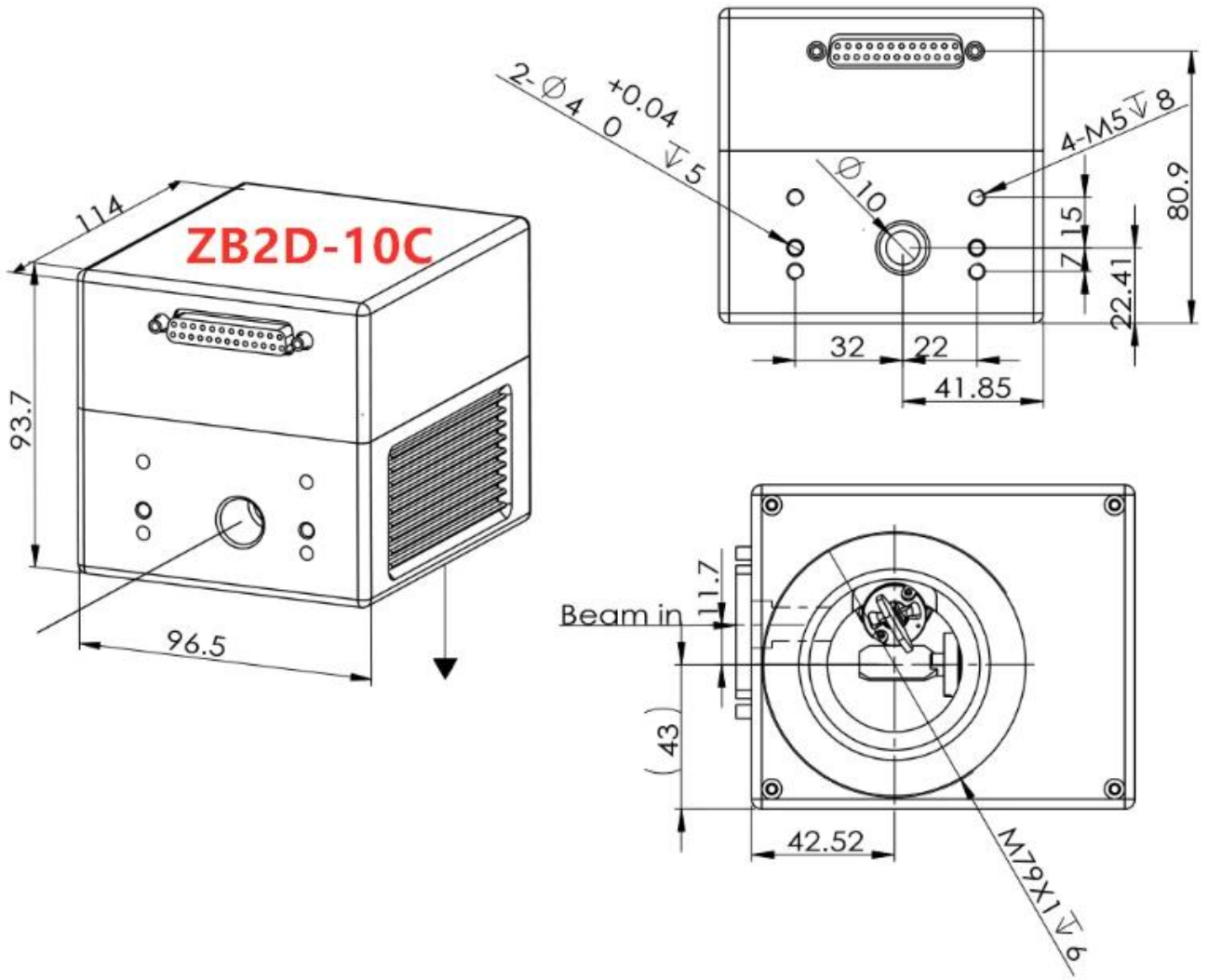

□□ □□□□ □□ :

屏蔽线接外壳

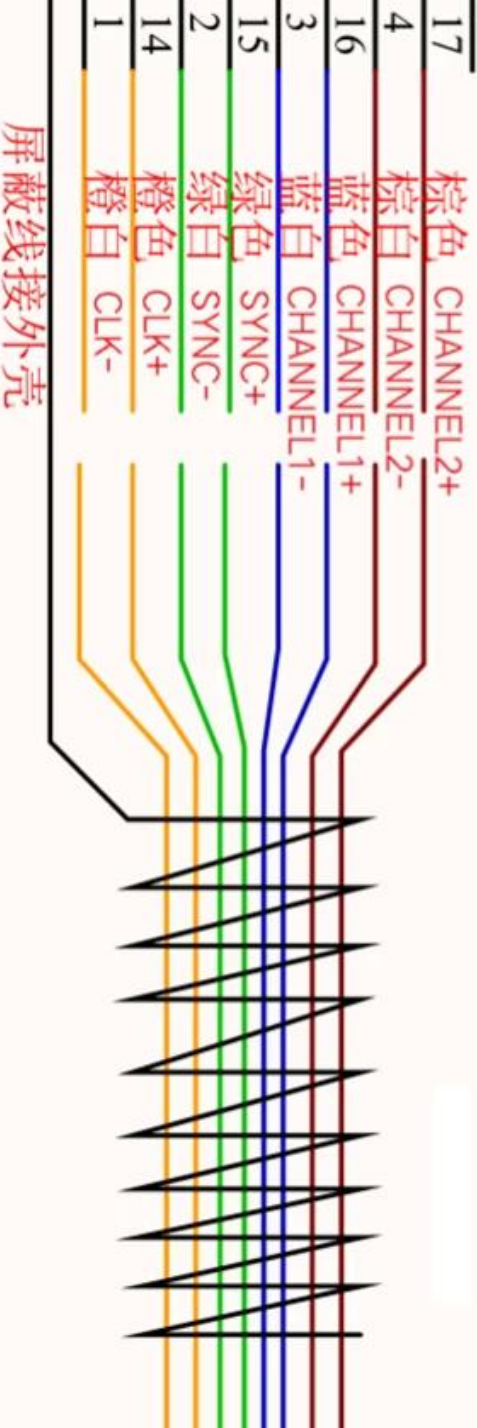
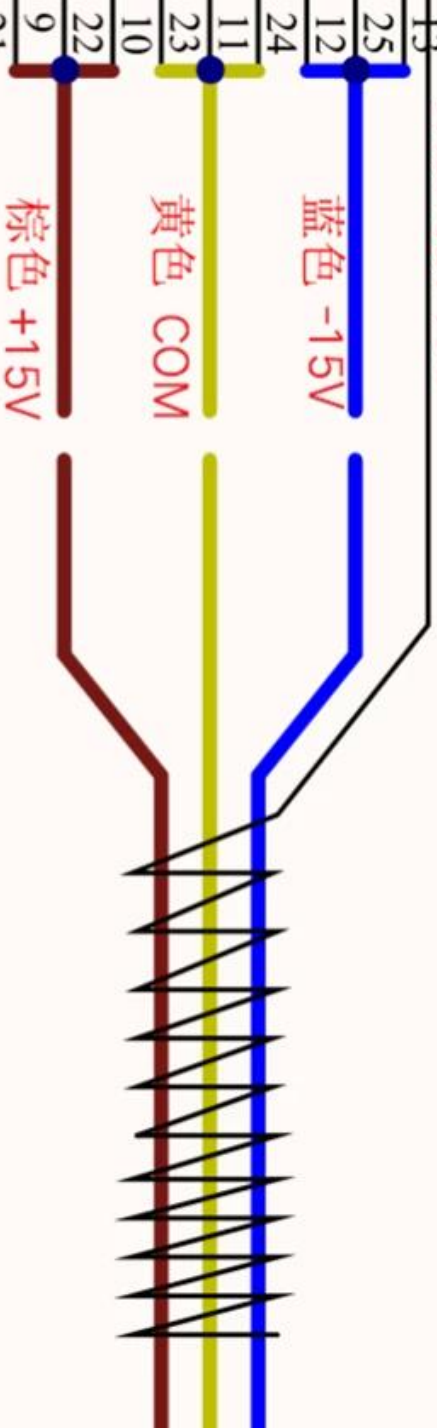

屏蔽线接外壳

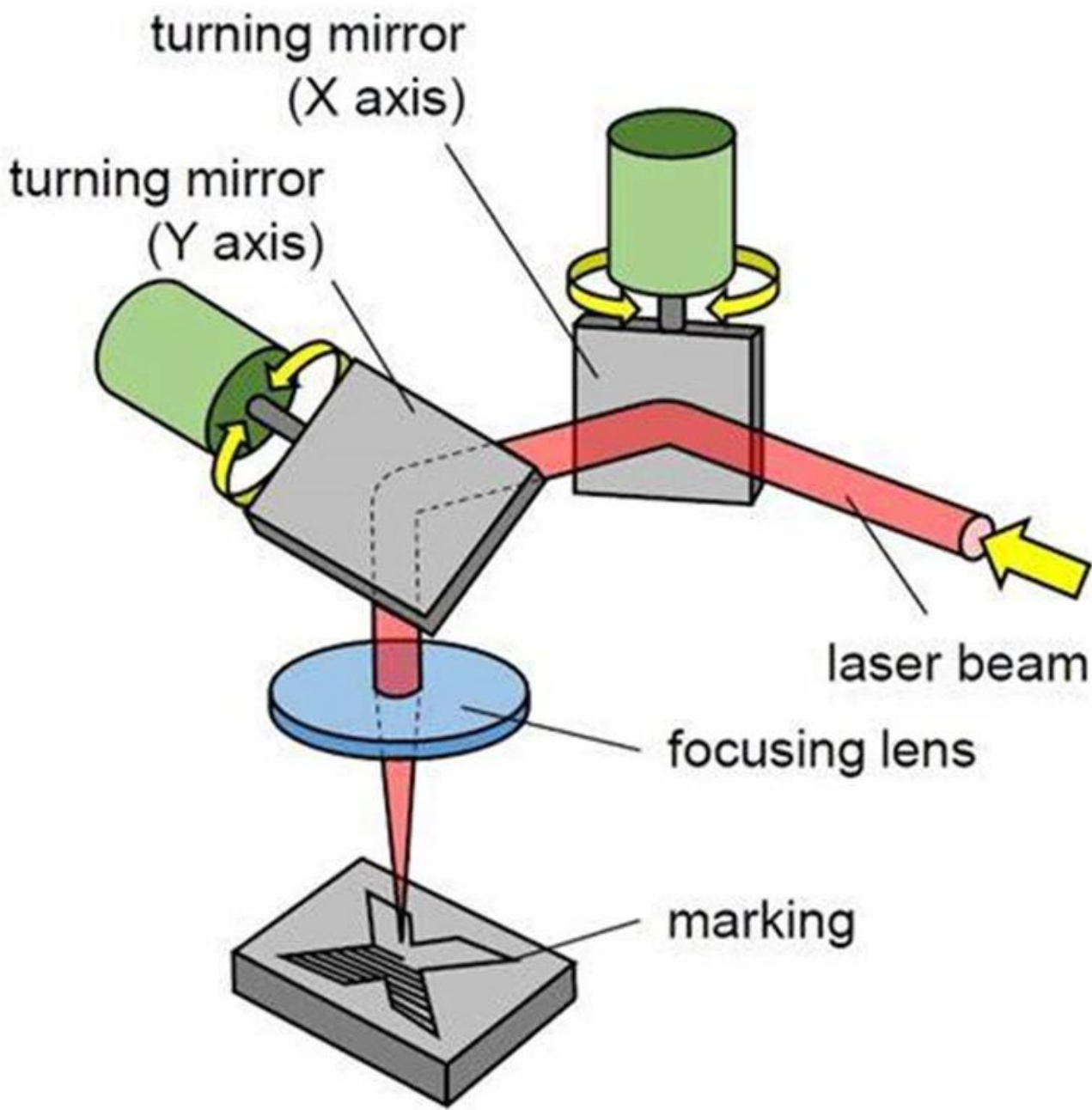

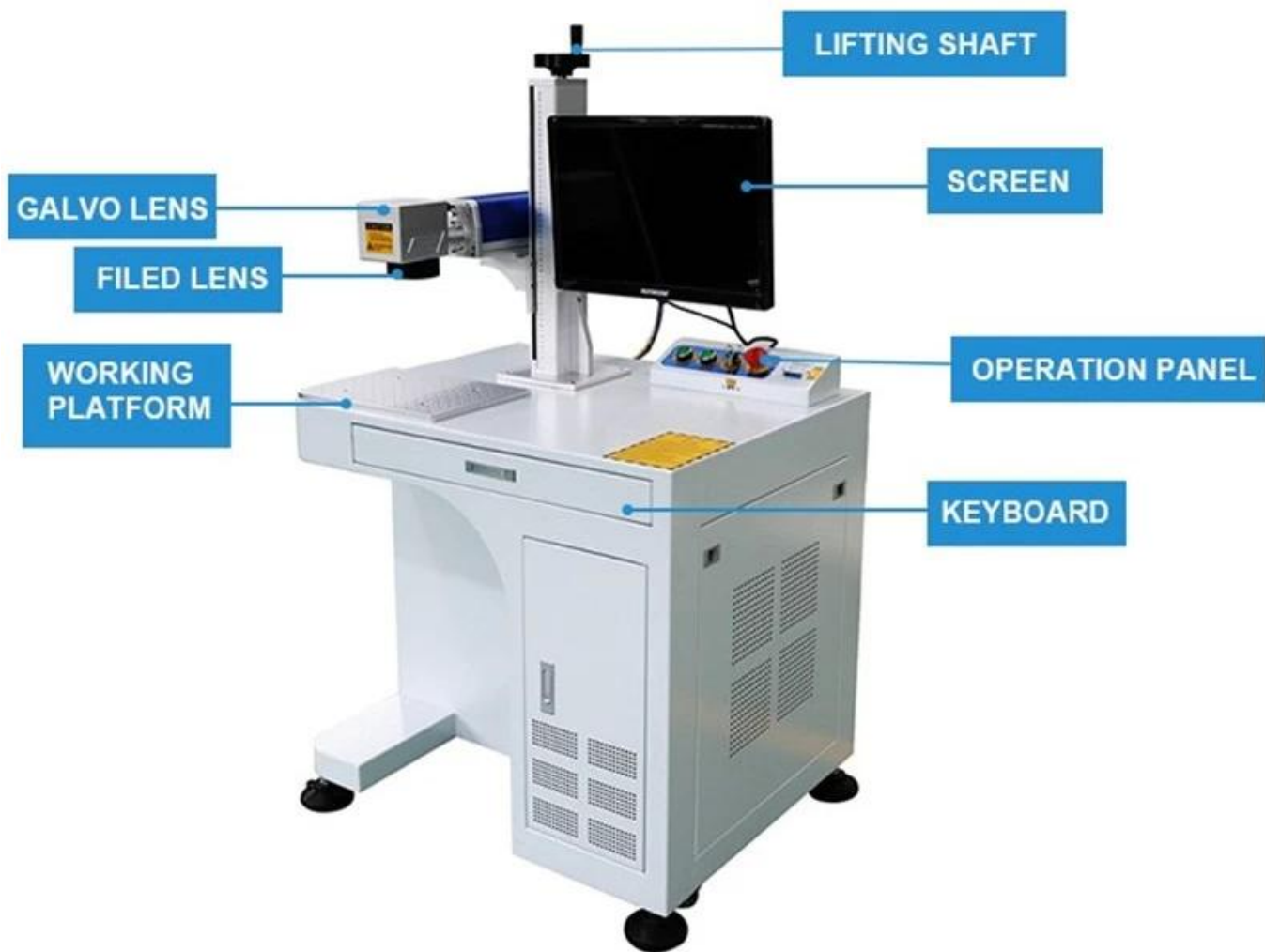











重要仪器,
非专业人士勿动。

OptiCentric 300

TRIOPTICS



PerkinElmer Lambda 950---Testing Transmission and Reflectivity







CERTIFICATE

ATTESTATION CERTIFICATE OF MACHINERY AND LOW VOLTAGE DIRECTIVES

Technical file of the company mentioned below has been observed and audit has been completed successfully. 2006/42/EC Machinery Directive and 2014/ 35/EU Low Voltage Directive have been taken as references for these processes

Company Name : **Camman HAAS Laser Technology (Suzhou) Co., Ltd.**

Company Address : No 155, West Road Suhong, Suzhou Industrial Park, Suzhou City, Jiangsu , P.R.China

Related Directives and Annex : **Low Voltage Directive 2014/35/EU
Machinery Directive 2006/42/EC**

Related Standards : **EN ISO 12100:2010; EN 60204-1:2006+A1:2009+AC:2010**

Product Name : **Laser Marking Machine**

Report No and Date : SD-90049717.09.08.2018

Product Brand/Model/Type : LMCH-3W,LMCH-5W,LMCH-10W,LMCH-15W,LMCH-20W,LMCH-25W,
LMCH-30W,LMCH-50W,LMCH-60W,LMCH-70W,LMCH-100W,
LMCH-120W,LMCH-150W,LMCH-200W,LMCH-300W,LMCH-500W

Certificate Number : **M.2018.201.N6073**

Initial Assessment Date : 10.08.2018

Registration Date : 13.08.2018

Reissue Date/No :

Expiry Date : **12.08.2023**

Signature
UDEM International Certification
Auditing Training Centre Industry
and Trade Inc. Co.



The validity of the certificate can be checked through www.udem.com.tr. The CE mark shown on the right can only be used under the responsibility of the manufacturer with the completion of EC Declaration of Conformity for all the relevant Directives. This certificate remains the property of UDEM International Certification Auditing Training Centre Industry and Trade Inc. Co. to whom it must be returned upon request. The above-mentioned firm must keep a copy of this certificate for 15 years from the registration of certificate. This certificate only covers the product(s) stated above and UDEM must be notified in case of any changes on the product(s).
Address: Murkazeri Mahallesi 2073 Sokak (Eski 93 Sokak) No:10 Çankaya - Ankara - TÜRKİYE
Phone: +90 0312 443 03 90 Fax: +90 0312 443 03 76
E-mail: info@udemtd.com.tr www.udem.com.tr



Certificate of Approval

Certificate No.: 10119Q12565ROM

Awarded to

**Carman Haas Laser Technology(SuZhou)
Co., Ltd.**

Organization Code Certificate No. / Unified Social Credit Code:91320594MA1MF4EP56
Add.:No.155, West Road Suhong, Suzhou Industrial Park, Suzhou City, Jiangsu Province, P.R. China. 215000

Beijing ZhongLianTianRun Certification Center (ZLTR) certify that the
Quality Management System of the above organization has been assessed and found to be
in accordance with the requirements of the standard:
GB/T19001-2016 / ISO9001:2015

SCOPE OF CERTIFICATION/REGISTRATION

The Research and Development and Production of Optics Lenses (Except the limits of national laws and regulations.)

This certificate is made valid when used with certification scopes and the requirements of applicable laws and regulations. These requirements include, but are not limited to, administrative permits, scopes of qualifications, and CCC requirements.

Subject to operation conditions in requirements conformity with Quality Management System.

This Certificate is valid for a period of three years only.

Date from: Mar 13th,2019 To: Mar 12th,2022

The effectiveness of this Certificate shall be Validated by periodic surveillance audit of ZLTR for maintenance.

Information of this certificate can be found on the official website of Beijing Zhonglian Tianrun Certification center (<http://www.zltr.com.cn>)

ISO 9001

ISO 9001



Beijing ZhongLiantianrun Certification Center

Room2003, 22nd Floor, 2nd Unit, Block 1, No.4 Yard, Qiyang Road, Chaoyang District, Beijing, P.R. China 100022

Information of the certificate can be found on the official website of Certification and Accreditation Administration of the People's Republic of China (<http://www.cca.gov.cn>)



Packaging & Shipping



Product Packaging





□□□□□□ :

- 1 □□)□ □ □□□ □□□□ □□□□□□□□.
- 2 □□) □□□ □□□ □□ □□□ □ □□ □□ □□□□□□□□.
- □□□□ 3 □□) □□□ □□□□□□□.
- 4) □□ □□ □□ □□ □□□ □□□□□□□.

□□ □□:

- (1) □□□ □□ □□ □□□ □ DHL, UPS, □□□, TNT, EMS□ □□ □ □□□
- (2) □□□ □□ □□ □□□ □□, □□□□ □□□ □□ □□□ □□ □ etc□ EXWORK, FOB, CNF, CIF□ □□ □□ □□ □□ □□ □□ □ □ □□□□.



□□□□ □□ □□ Q1.Are?

A1 : □, □□□ □□□□□ □□□ □□□ □ □□ □□□ □□ □ □□ □□.

□□□ □□□ □□ Q2.How?

A2□ : □□□ □□□□ QC □□ □□ □□□ □□ □□□ □□□ □□, □□ □□ □ □□ □□ □□ □□ □□□□ □□□ □□□□□□□.

□□□ □□ Q3.How?

A3 : □□□ □□ □□ □ □□ □□□ □□□□ □□ □□□□□ □□□ □□□□□.

Q4.How □□□ □□□?

A4□ : □□ □□□□ □□□ □□□ □□ □□ □□□□ □□, □□□ □ □ □□, □□ □□, □□□ □□□□ □□ □□ □□□□. □□□□□□.

Q5.May □□ □□ □□ □□□ □□□ □□?

A5 : □! □□□ □□□ □□□ □□□ □□□□□ □□ □□□ □□ □□□□□.

Q6.Can □□ □□□ □□□ □□?

A6 : □, □□□ □□□ □□□ □□□ □□□ □□□□□.

Q7.How □□ OEM □□ ODM □□□ □ □ □□□□?

A7 : □□□ □□ OEM□ □□ □□ □□ □□ □□ / ODM ORDERS. □□□ □□□□ □□□□ □□ □□□ □□□ □□ □□□ □□□□.

Q8. □□□ □□□ □□ □□□ □□□□□□□?

A8 : □□□ T□ □□ □□ □ □ / T□ □□□ □□ □□□ □□□□ □ □ MOQ□ □ □□□ □□□□□.