

## Product Information

### Product Description:

Carmanhaas has high end 2D laser scanning galvanometer, 3D laser scanning galvanometer, high power laser welding galvanometer, beauty galvanometer and laser cleaning solution. ([UV F-theta Lens manufacturer china](#))

Carmanhaas 2-axis Galvanometer Scanner Head including High Speed (A Series) and Standard Series, are designed for a board range of application including laser precision marking, laser cutting, laser welding, rapid prototyping, 3D printing, drilling location, laser cleaning, medical beauty and so on.

### Features:

- 1.Aperture: 7mm, 10mm, 12mm, 14mm, 16mm, 20mm, 30mm□
- 2.Good degree of Linearity, high resolution small drift, precise repetitive positioning□
- 3.Highest processing speeds in the industry to maximize production throughput□
- 4.High-accuracy & high-stability models available for precise scanning applications□
- 5.Wide range of cost-efficient, high-performance options for specific applications.

Understand more:[355 Galvo Scanner Price China](#)

## PRODUCT DETAILS

HIGH SPEED  
GALVO LENS

NO.1

SMALL SIZE, FRIENDLY INTERFACE  
IN ORDER TO IMPROVE THE QUALITY OF EXPORT,  
USE NEW TECHNOLOGY, NEW CRAFT, IN THE GALVO  
LENS SCANNING SYSTEM, GRAPHIC IS GOOD, NO DISTORION ETC...

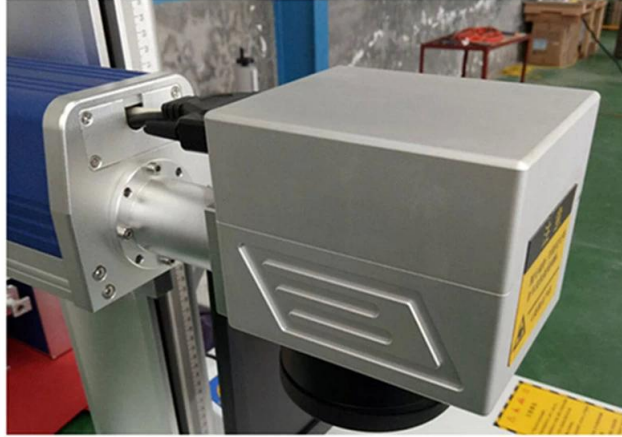

FILED LENS SCANNING SYSTEM TO ADOPT NEW TECHNOLOGY  
IMPORTED SCANNING SYSTEM MAKES THE SCANNING SPEED IS  
UP TO 7000 MM/S

FILED LENS





CARMAN HAAS

## F-theta Lens

Own unique designs with different focal length

Getting a smaller spot size what you demand



### Detail Image





### Technical Parameters:

Model	ZB2D-10A	ZB2D-10C
Aperture (mm)	10	10
Typical scan angle	$\pm 0.35$ rad	$\pm 0.35$ rad
Nonlinearity	$< 0.5$ mrad	$< 2$ mrad
Tracking error	0.15ms	$< 0.2$ ms
Step Response Time	$< 0.3$ ms	$< 0.4$ ms
Repeatability	$< 15$ urad	$< 20$ urad
Gain drift	$< 50$ ppm/K	$< 50$ ppm/K
Zero drift	$< 30$ urad/K	$< 30$ urad/K
Long-term drift over 8hours [After 30 min warn-up]	$< 0.1$ mrad	$< 0.1$ mrad
Marking speed	4000mm/s	8000mm/s
Positioning speed	15m/s	10m/s
Power requirements	$\pm 15$ VDC Max.5A	$\pm 15$ VDC Max.3A
Digital Signal	XY2-100	XY2-100 or SPI
Analog Signal	$\pm 5$ V	$\pm 5$ V or $\pm 10$ V
Reflection wavelength	355nm	

Operating temperature	25°C±10°C	25°C±10°C
-----------------------	-----------	-----------

### UV Laser F-Theta Scan Lenses (355nm)

Part Description	FL(mm)	Scan Field (mm)	Max Entrance Pupil (mm)	Working Distance (mm)	Mounting Thread
SL-355-70-100	100	70x70	10	134	M85x1
SL-355-110-170	170	110x110	10	217.6	M85x1
SL-355-150-210	210	150x150	10	249	M85x1
SL-355-175-254	254	175x175	10	306.7	M85x1
SL-355-220-330	330	220x220	10	384.2	M85x1
SL-355-300-420	420	300x300	10	482.3	M85x1
SL-355-360-580	580	360x360	16	660	M85x1
SL-355-520-750	750	520x520	10	824.4	M85x1
SL-355-610-840-(15CA)	840	610x610	15	910	M85x1
SL-355-800-1090-(18CA)	1090	800x800	18	1193	M85x1

### Mechanical Dimensions(mm)

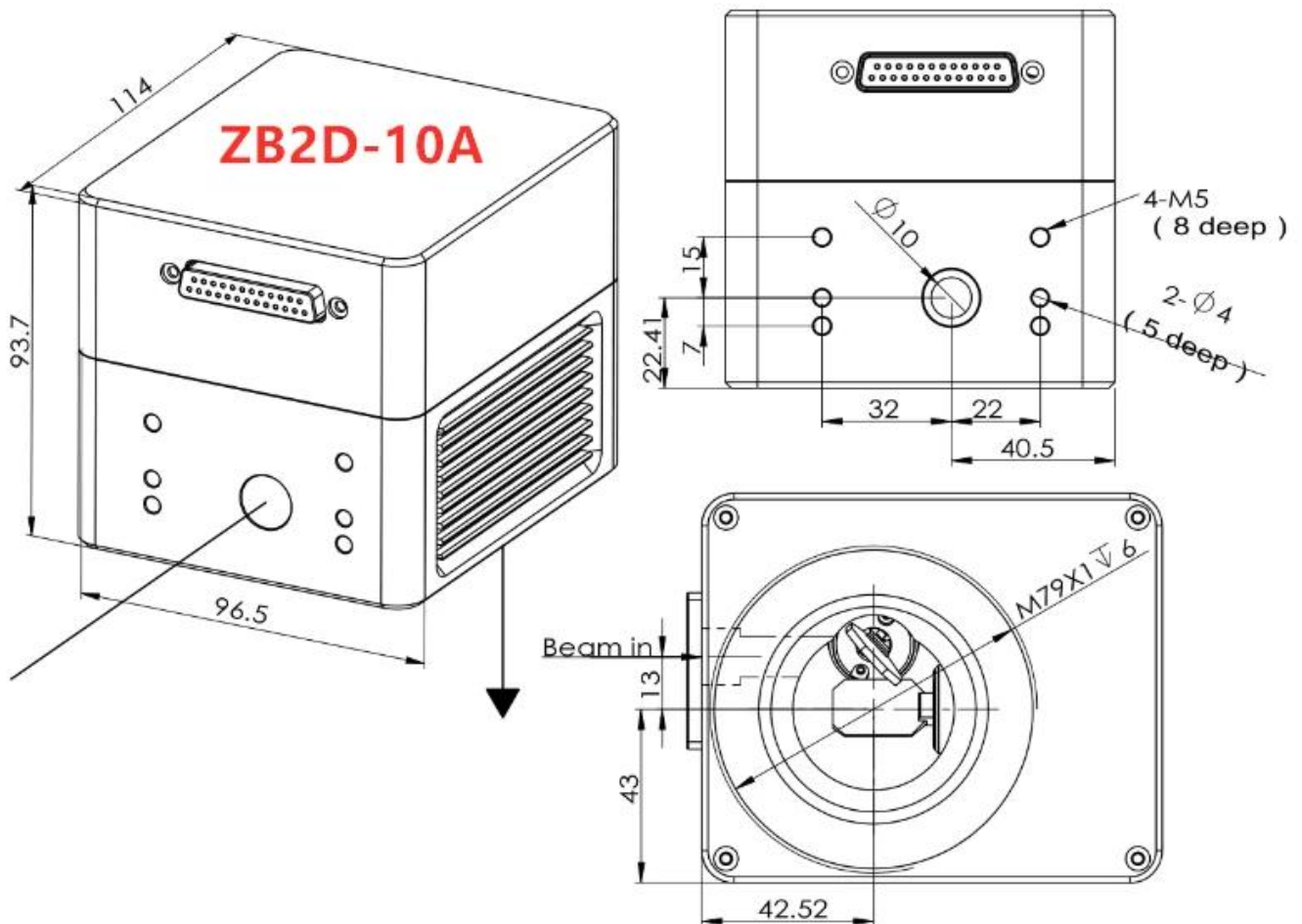

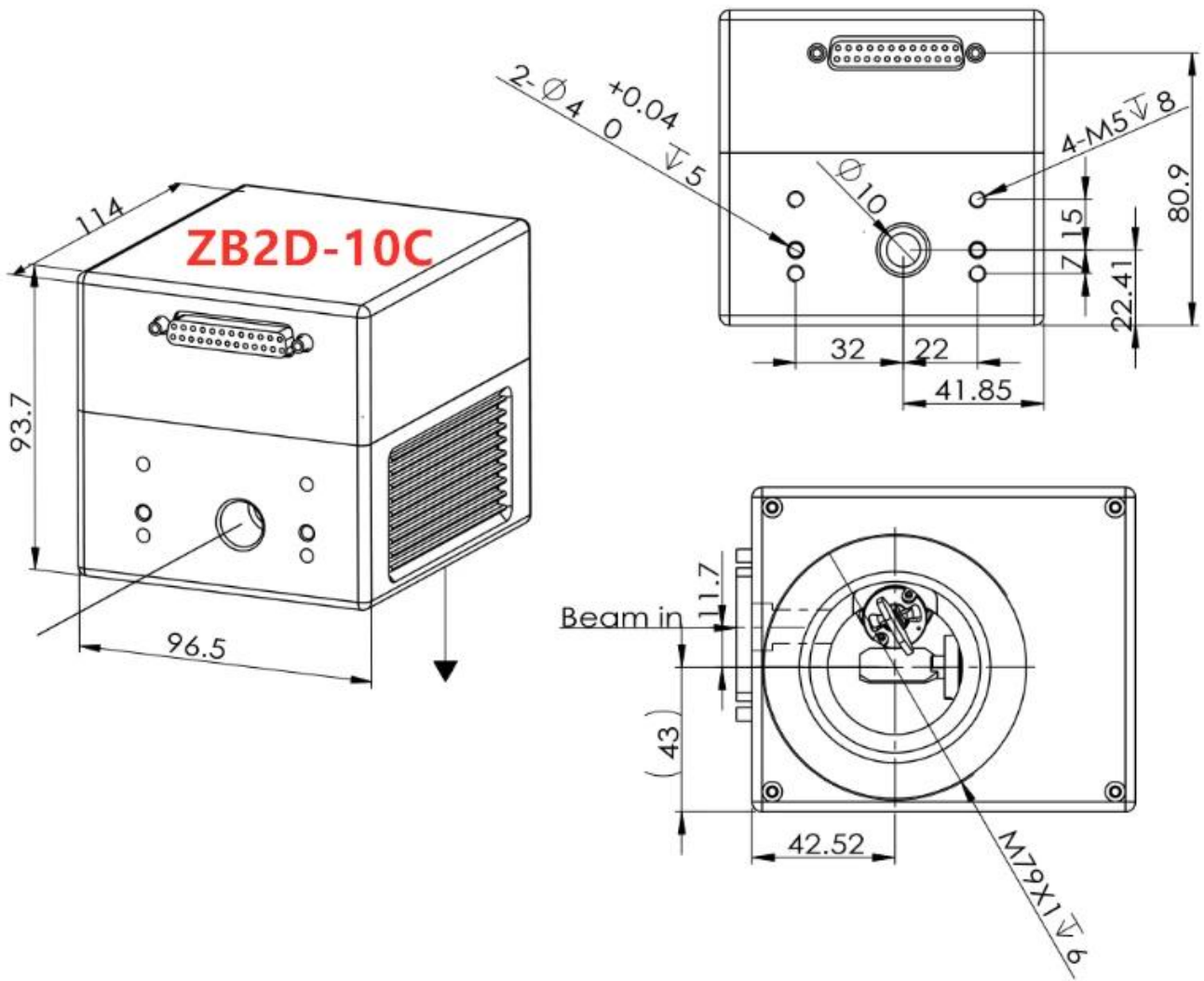

**Electrical interface definition:**

屏蔽线接外壳

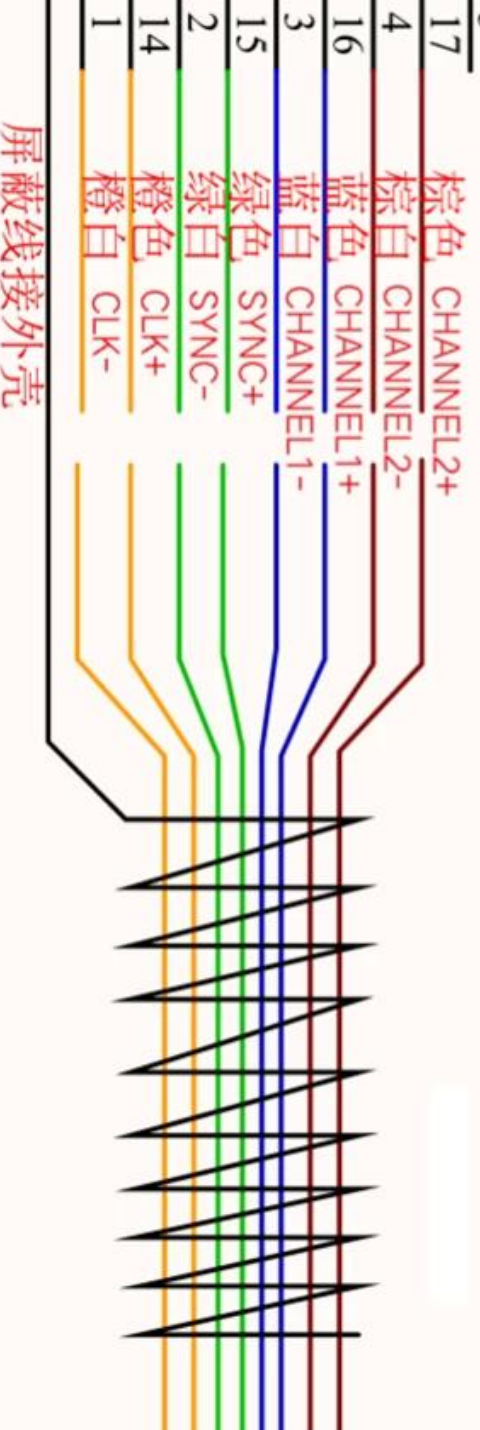
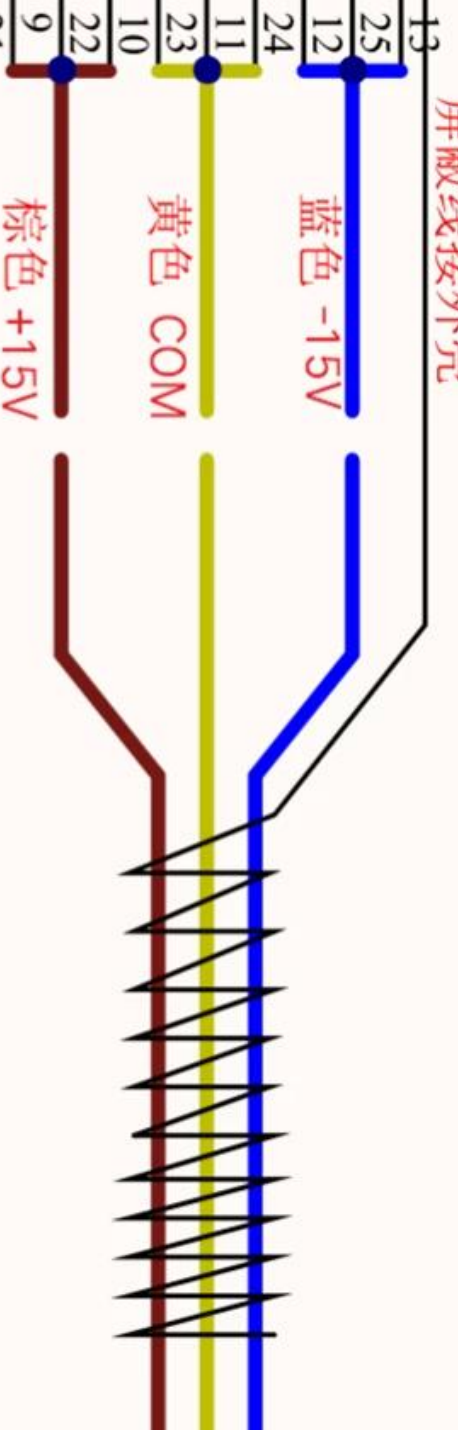

屏蔽线接外壳

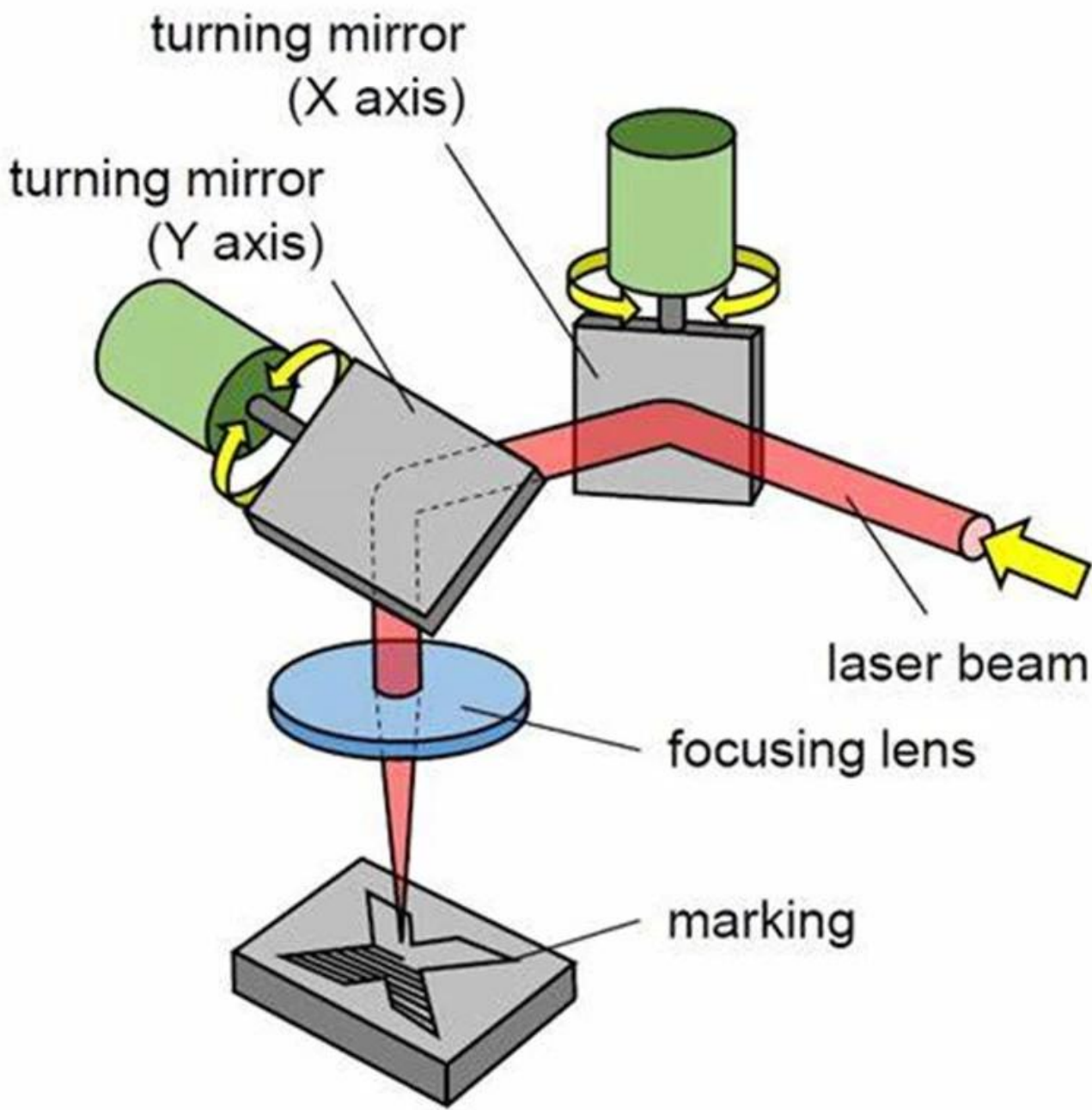



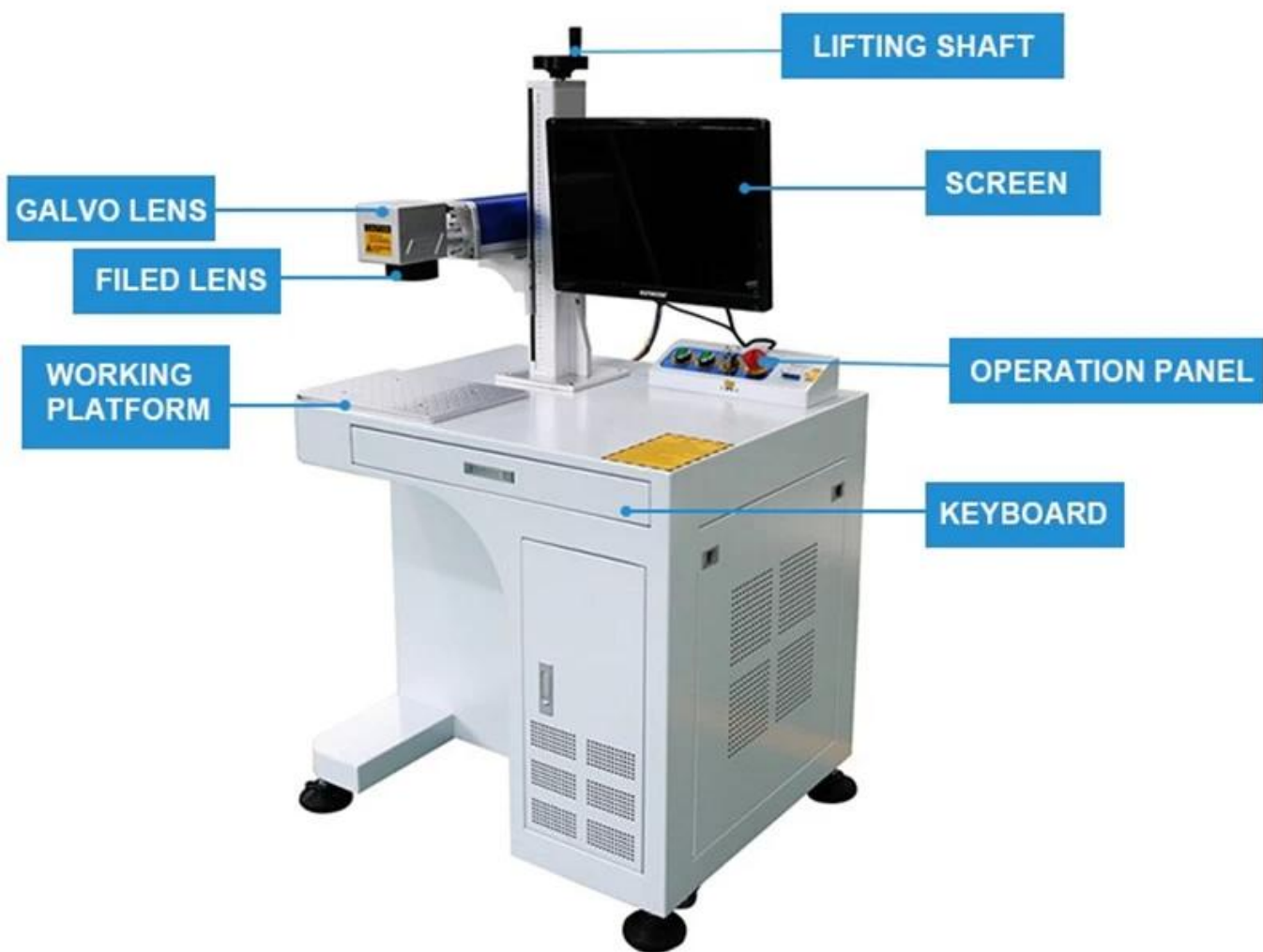





[UV F-theta lens factory china](#)

Factory







重要仪器,  
非专业人士勿动。

OptiCentric 300

TRIOPTICS





PerkinElmer Lambda 950---Testing Transmission and Reflectivity



# Certificate&Exhibition







# C E R T I F I C A T E

## ATTESTATION CERTIFICATE OF MACHINERY AND LOW VOLTAGE DIRECTIVES

Technical file of the company mentioned below has been observed and audit has been completed successfully. 2006/42/EC Machinery Directive and 2014/ 35/EU Low Voltage Directive have been taken as references for these processes

Company Name : **Camman HAAS Laser Technology (Suzhou) Co., Ltd.**

Company Address : No 155, West Road Suhong, Suzhou Industrial Park, Suzhou City, Jiangsu , P.R.China

Related Directives and Annex : **Low Voltage Directive 2014/35/EU  
Machinery Directive 2006/42/EC**

Related Standards : **EN ISO 12100:2010; EN 60204-1:2006+A1:2009+AC:2010**

Product Name : **Laser Marking Machine**

Report No and Date : SD-90049717.09.08.2018

Product Brand/Model/Type : LMCH-3W,LMCH-5W,LMCH-10W,LMCH-15W,LMCH-20W,LMCH-25W,  
LMCH-30W,LMCH-50W,LMCH-60W,LMCH-70W,LMCH-100W,  
LMCH-120W,LMCH-150W,LMCH-200W,LMCH-300W,LMCH-500W

Certificate Number : **M.2018.201.N6073**

Initial Assessment Date : 10.08.2018

Registration Date : 13.08.2018

Reissue Date/No :

Expiry Date : **12.08.2023**

*Signature*  
UDEM International Certification  
Auditing Training Centre Industry  
and Trade Inc. Co.



The validity of the certificate can be checked through [www.udem.com.tr](http://www.udem.com.tr). The CE mark shown on the right can only be used under the responsibility of the manufacturer with the completion of EC Declaration of Conformity for all the relevant Directives. This certificate remains the property of UDEM International Certification Auditing Training Centre Industry and Trade Inc. Co. to whom it must be returned upon request. The above-mentioned firm must keep a copy of this certificate for 15 years from the registration of certificate. This certificate only covers the product(s) stated above and UDEM must be notified in case of any changes on the product(s).  
Address: Mithakere Mahalleli 2073 Sokak (Eski 93 Sokak) No:10 Çankaya - Ankara - TÜRKİYE  
Phone: +90 0312 443 03 90 Fax: +90 0312 443 03 76  
E-mail: [info@udemtd.com.tr](mailto:info@udemtd.com.tr) [www.udem.com.tr](http://www.udem.com.tr)



## Certificate of Approval

Certificate No.: 10119Q12565ROM

Awarded to

**Carman Haas Laser Technology(SuZhou)  
Co., Ltd.**

Organization Code Certificate No. / Unified Social Credit Code:91320594MA1MF4EP56  
Add.:No.155, West Road Suhong, Suzhou Industrial Park, Suzhou City, Jiangsu Province, P.R. China. 215000

Beijing ZhongLianTianRun Certification Center (ZLTR) certify that the  
Quality Management System of the above organization has been assessed and found to be  
in accordance with the requirements of the standard:  
**GB/T19001-2016 / ISO9001:2015**

### SCOPE OF CERTIFICATION/REGISTRATION

The Research and Development and Production of Optics Lenses (Except the limits of national laws and regulations.)

This certificate is made valid when used with certification scopes and the requirements of applicable laws and regulations. These requirements include, but are not limited to, administrative permits, scopes of qualifications, and CCC requirements.

Subject to operation conditions in requirements conformity with Quality Management System.

This Certificate is valid for a period of three years only.

**Date from: Mar 13th,2019 To: Mar 12th,2022**

The effectiveness of this Certificate shall be Validated by periodic surveillance audit of ZLTR for maintenance.

Information of this certificate can be found on the official website of Beijing Zhonglian Tianrun Certification center (<http://www.zltr.com.cn>)



Beijing Zhongliantianrun Certification Center

Room2003, 22nd Floor, 2nd Unit, Block 1, No.4 Yard, Qiyang Road, Chaoyang District, Beijing, P.R. China 100022

Information of the center can be found on the official website of Certification and Accreditation Administration of the People's Republic of China (<http://www.cnca.gov.cn>)

ISO 9001

ISO 9001

# Packing List

## Packaging & Shipping



# Product Packaging





**Return Policy:**

Should returns be required:

Step 1) Contact us with this website email.

Step 2) Provide as much detail as possible about the problem you are having.

Step 3) Authorization to return the item will be issued.

Step 4) Return the item for the agreed replacement or refund.

## **Logistics:**

(1)For Laser Optics order delivery,can be optional with DHL, UPS, FedEx, TNT, EMS etc

(2)For Laser machine order delivery, can be optional with terms of EXWork, FOB, CNF, CIF By Air or by Sea based on the buyer's forwarders or ours.

## FAQ

Q1.Are you a manufacturer?

A1: Yes, we are professional and experienced manufacturer with our own molds and production lines.

Q2.How about quality of products?

A2: Our technicians and QC teams test the products one by one using aging line, professional devices and instruments to ensure the quality for all products.

Q3.How about price?

A3: We are a manufacturer and always offer our customers the most competitive prices.

Q4.How to place an order?

A4: Contact with online service, or sent email to us directly, we will reply to you with product price, specifications, packing etc. soon. Thank you.

Q5.May I send material to test marking performance?

A5: Yes! You are welcome to send material to test our superior quality and service.

Q6.Can I visit your factory?

A6: Yes, welcome to visit our factory at your convenient time.

Q7.How can I make OEM or ODM orders?

A7: We have different print processing for different OEM/ODM orders. Please contact us with online service or send email to us directly.

Q8. How should I pay for my orders?

A8: You can pay by T/T would be available for qualified bank and MOQ required for each order.