

Product Description

Lasers can provide high-speed cleaning and surface preparation in virtually all industries. The low-maintenance, easily automated process can be used to remove oil and grease, strip paint or coatings, or modify surface texture, for example adding roughness to increase adhesion.

Carmanhaas [Optics lens for laser cleaning gun manufacturers](#) offer professional laser cleaning system. Commonly used optical solutions: the laser beam scans the working surface through the galvanometer system and the scan lens to clean the entire working surface. Widely used in metal surface cleaning, special energy laser sources can also be applied to non-metallic surface cleaning.

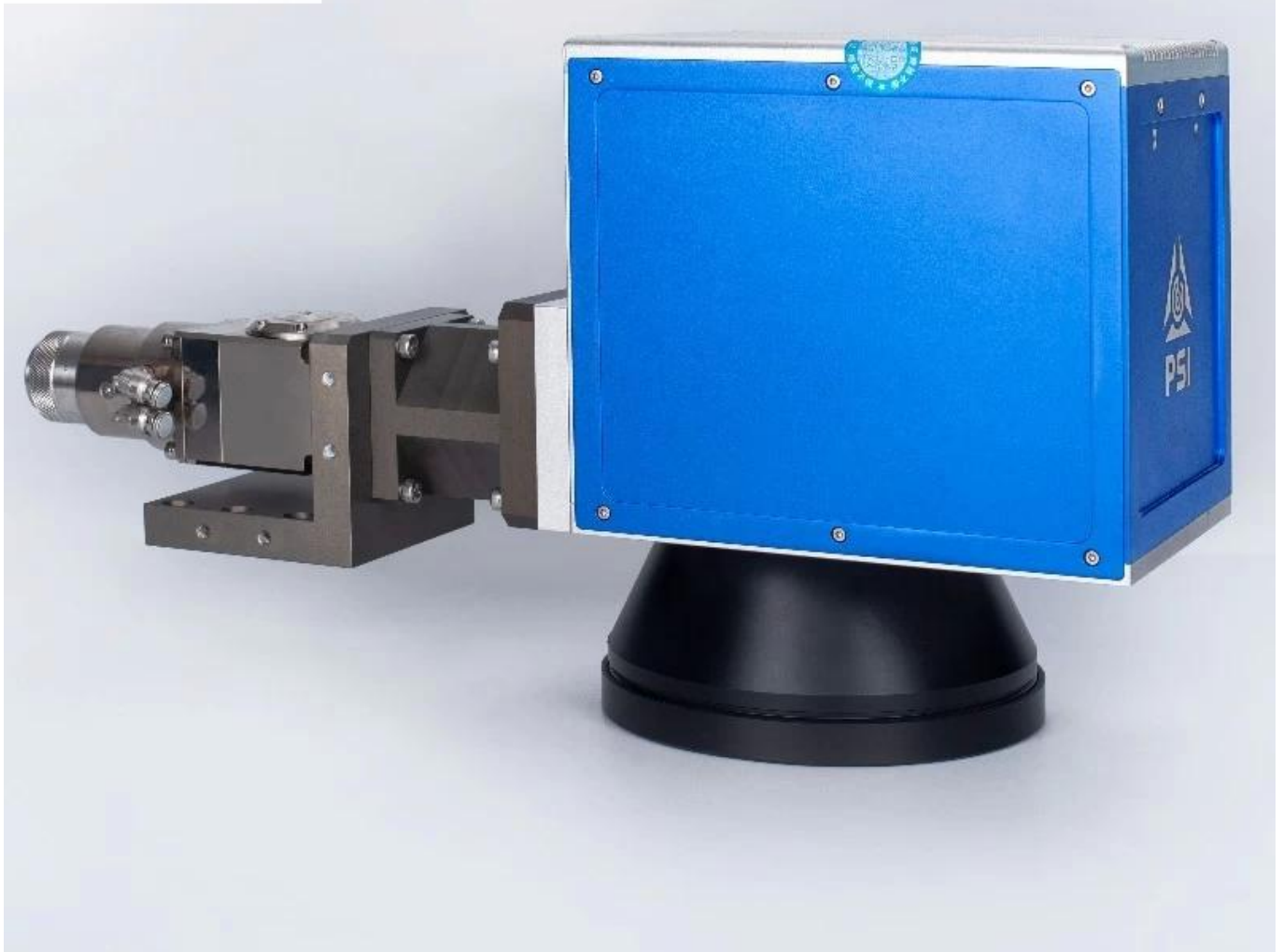

Carmanhaas [China Laser cleaning equipment on sales supplier](#) optical components mainly include QBH collimation module, galvanometer system and F-THETA scan lens. QBH collimation module converts the diverging laser beam into a parallel beam (reducing the divergence angle), galvanometer system realizes beam deflection and scanning, and F-Theta scan lens achieves uniform beam scanning focus.

Advantage:

- 1.No abrasive materials are used, with no problems of contaminant separation and disposal;
- 2.No solvents are used - chemical-free and environmentally friendly process;
- 3.Spatially selective - cleaning only the area required, saving time and costs by ignoring regions that don't matter;
- 4.Non-contact process never degrades in quality;
- 5.Easily automated process that can lower operating costs by eliminating labor while giving greater consistency in results.

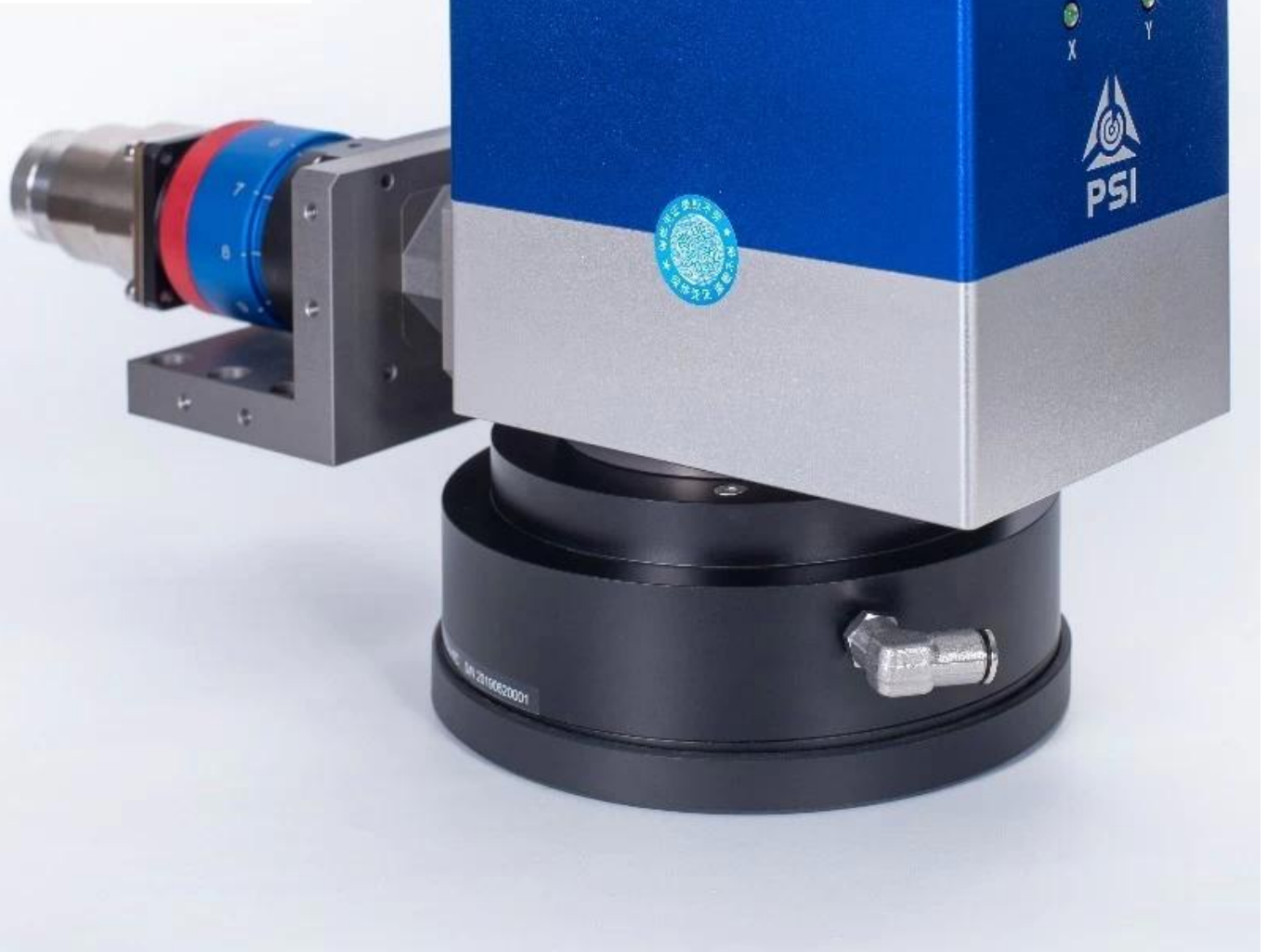

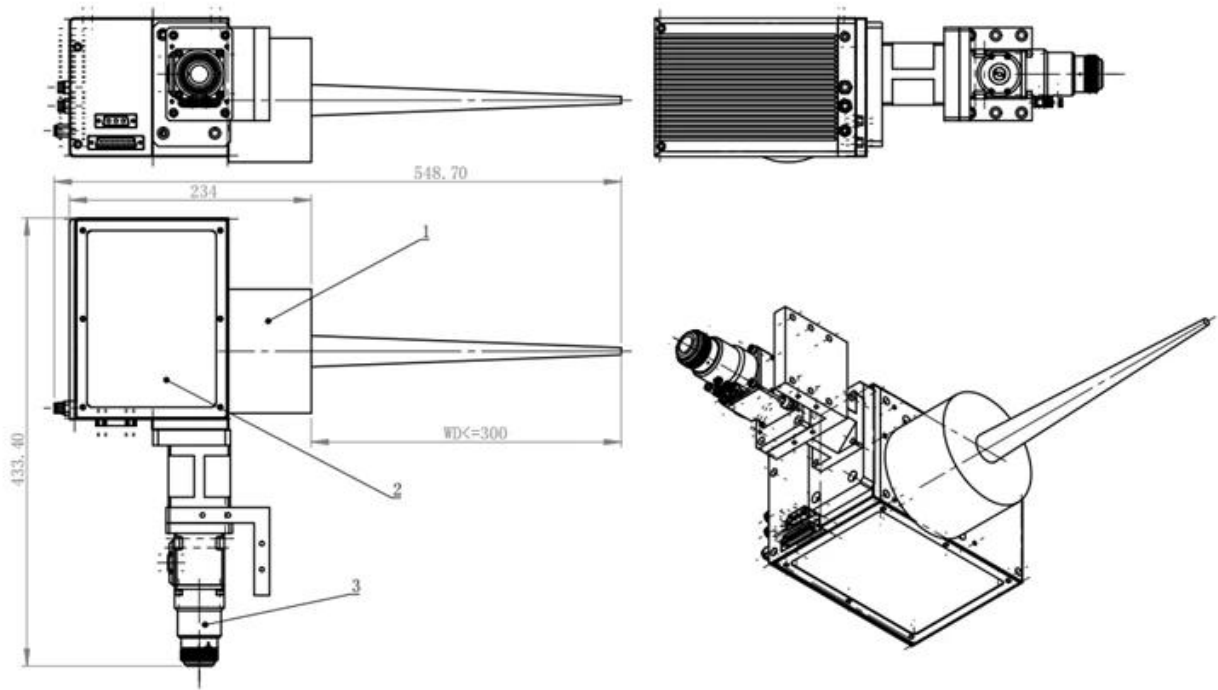

Technical Parameters

Model	PSH14HW	PSH20HW
Maximum allowed average laser power(1)	1000W	2000W
Damage threshold for pulsed operation(1)	30J/ cm ²	30J/ cm ²
Cooling	Water cooling	Water cooling
Aperture (mm)	14	20
Effective Scan Angle(2)	±12 °	±12°
Tracking Error	≤ 0.2ms	≤ 0.28ms
Step Response Time(1% of full scale)	≤ 0.4 ms	≤ 0.7 ms
Positioning/ jump(3)	< 15 m/s	< 9 m/s
Precision marking speed(4)	< 3 m/s	< 2 m/s
Good writing quality(3) (4)	650 cps	450 cps
High writing quality(3) (4)	500 cps	300 cps
Linearity	99.9%	99.9%
Repeatability	≤ 3 urad	≤ 3 urad
Over 8 hours long-term offset drift (after 10 min warm-up)	≤ 30 urad	≤ 30 urad
Over 8 hours long-term gain drift (after 10 min warm-up)	≤ 30 urad	≤ 30 urad
Operating Temperature Range	25°C±10°C	25°C±10°C
Signal Interface	Analog: ±10V Digital: XY2-100 protocol	Analog: ±10V Digital: XY2-100 protocol

Input Power Requirement (DC)	±15V@ 4A Max RMS	±15V@ 4A Max RMS
------------------------------	------------------	------------------

Note:

- (1) Applicable for wavelength 1030-1090nm.
- (2) All angles are in mechanical degrees.
- (3) With F-Theta objective f = 163mm. Speed value varies correspondingly with different focal lengths.
- (4) Repeatability and temperature drift are measured within this speed.
- (5) Single-stroke font with 1 mm height.

QBH collimating optical module 1030nm - 1090nm:

Part Description	Focal Length (mm)	Clear Aperture (mm)	NA	Coating
CL2-(1030-1090)-30-F60-QBH-A-WC	60	28	0.22	AR/AR@1030-1090nm
CL2-(1030-1090)-30-F75-QBH-A-WC	75	28	0.17	AR/AR@1030-1090nm
CL2-(1030-1090)-30-F100-QBH-A-WC	100	28	0.13	AR/AR@1030-1090nm
CL2-(1030-1090)-30-F125-QBH-A-WC	125	28	0.1	AR/AR@1030-1090nm
CL2-(1030-1090)-30-F150-QBH-A-WC	150	28	0.09	AR/AR@1030-1090nm

Note:

According Laser Source Core Diameter and BBP choose correct Collimating lens

1030nm - 1090nm F-Theta Lens:

Part Description	Focal Length (mm)	Scan Field (mm)	Max Entrance Pupil (mm)	Working Distance(mm)	Mounting Thread
SL-(1030-1090)-105-170-(15CA)	170	105x105	15	215	M85x1
SL-(1030-1090)-150-210-(15CA)	210	150x150	15	269	M85x1
SL-(1030-1090)-175-254-(15CA)	254	175x175	15	317	M85x1
SL-(1030-1090)-180-340-(30CA)-M102*1-WC	340	180x180	30	417	M102x1
SL-(1030-1090)-180-400-(30CA)-M102*1-WC	400	180x180	30	491	M102x1
SL-(1030-1090)-250-500-(30CA)-M112*1-WC	500	250x250	30	607	M102x1

Note: *WC means Scan Lens with water-cooling system

Why are more manufacturers using laser cleaning for material preparation?

Laser cleaning offers multiple advantages over traditional approaches. It does not involve solvents and there is no abrasive material to be handled and disposed of. Compared with other processes that are less detailed, and frequently manual processes, laser cleaning is controllable and can be applied only to specific areas of a part, can be easily automated to maximize productivity, and provides the guaranteed repeatability demanded by an increasing number of quality standards.

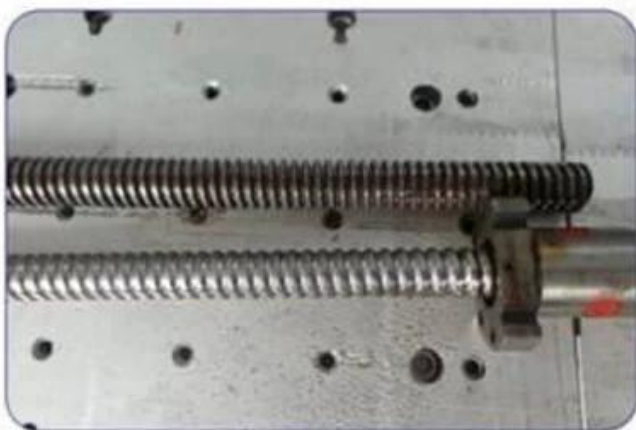
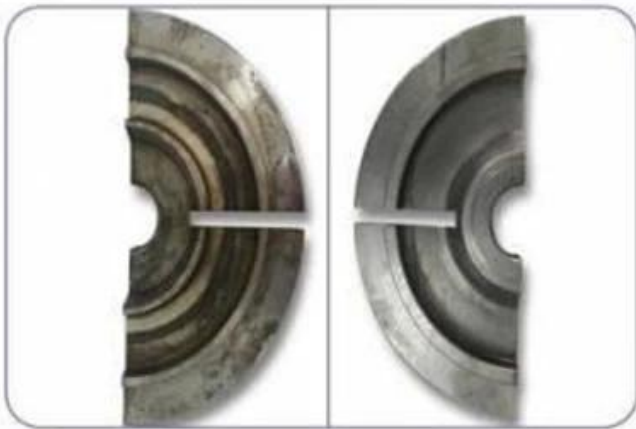



BEFORE

AFTER

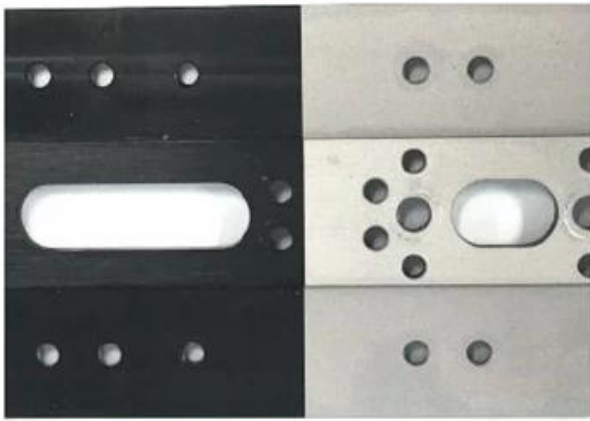

BEFORE

AFTER



BEFORE

AFTER



BEFORE



AFTER



BEFORE

AFTER

Factory







重要仪器,
非专业人士勿动。

OptiCentric 300

TRIOPTICS



PerkinElmer Lambda 950---Testing Transmission and Reflectivity



Certificate&Exhibition



C E R T I F I C A T E

ATTESTATION CERTIFICATE OF MACHINERY AND LOW VOLTAGE DIRECTIVES

Technical file of the company mentioned below has been observed and audit has been completed successfully. 2006/42/EC Machinery Directive and 2014/35/EU Low Voltage Directive have been taken as references for these processes

Company Name : **Camman HAAS Laser Technology (Suzhou) Co., Ltd.**

Company Address : No 155, West Road Suhong, Suzhou Industrial Park, Suzhou City, Jiangsu , P.R.China

Related Directives and Annex : **Low Voltage Directive 2014/35/EU
Machinery Directive 2006/42/EC**

Related Standards : **EN ISO 12100:2010; EN 60204-1:2006+A1:2009+AC:2010**

Product Name : **Laser Marking Machine**

Report No and Date : **SD-90049717.09.08.2018**

Product Brand/Model/Type : **LMCH-3W,LMCH-5W,LMCH-10W,LMCH-15W,LMCH-20W,LMCH-25W,
LMCH-30W,LMCH-50W,LMCH-60W,LMCH-70W,LMCH-100W,
LMCH-120W,LMCH-150W,LMCH-200W,LMCH-300W,LMCH-500W**

Certificate Number : **M.2018.201.N6073**

Initial Assessment Date : **10.08.2018**

Registration Date : **13.08.2018**

Reissue Date/No :

Expiry Date : **12.08.2023**

U. Singh
UDM International Certification
Auditing Training Centre Industry
and Trade Inc. Co.

The validity of the certificate can be checked through www.udem.com.tr. The CE mark shown on the right can only be used under the responsibility of the manufacturer with the completion of EC Declaration of Conformity for all the relevant Directives. This certificate remains the property of UDEM International Certification Auditing Training Centre Industry and Trade Inc. Co. to whom it must be returned upon request. The above named firm must keep a copy of this certificate for 10 years from the registration of certificate. This certificate only covers the product(s) stated above and UDEM must be notified in case of any changes on the product(s).
Address: Mithakeet Mahabul 2073 Sokak (Eski 93 Sokak) No:10 Çankaya - Ankara - TÜRKİYE
Phone: +90 0312 443 03 90 Fax: +90 0312 443 03 76
E-mail: info@udemtd.com.tr www.udem.com.tr



Certificate of Approval

Certificate No.: 10119Q1256SR0M

Awarded to

**Carman Haas Laser Technology(SuZhou)
Co., Ltd.**

Organization Code Certificate No. / Unified Social Credit Code:91320594MA1MF4EP56
Add.No.155, West Road Suhong, Suzhou Industrial Park, Suzhou City, Jiangsu Province, P.R. China. 215000

Beijing ZhongLianTianRun Certification Center (ZLTR) certify that the
Quality Management System of the above organization has been assessed and found to be
in accordance with the requirements of the standard:
GB/T19001-2016 / ISO9001:2015

SCOPE OF CERTIFICATION/REGISTRATION

The Research and Development and Production of Optics Lenses (Except the limits of national laws and regulations.)

This certificate is made valid when used with certification scopes and the requirements of applicable laws and regulations. These requirements include, but are not limited to, administrative permits, scopes of qualifications, and CCC requirements.

Subject to operation conditions in requirements conformity with Quality Management System,

This Certificate is valid for a period of three years only,

Date from: Mar 13th,2019 To: Mar 12th,2022

The effectiveness of this Certificate shall be Validated by periodic surveillance audit of ZLTR for maintenance.

Information of this certificate can be found on the official website of Beijing Zhonglian Tianrun Certification center (<http://www.zltr.com.cn>)



Beijing ZhongLiantianrun Certification Center

Room2003, 22nd Floor, 2nd Unit, Block 1, No.4 Yard, Qiyang Road, Chaoyang District, Beijing, P.R. China 100022

Information of the center can be found on the official website of Certification and Accreditation Administration of the People's Republic of China (<http://www.cnca.gov.cn>)

ISO 9001

ISO 9001



Packaging & Shipping



Return Policy:

Should returns be required:

Step 1) Contact us with this website email.

Step 2) Provide as much detail as possible about the problem you are having.

Step 3) Authorization to return the item will be issued.

Step 4) Return the item for the agreed replacement or refund.

Logistics:

(1)For Laser Optics order delivery,can be optional with DHL,UPS,FedEx,TNT,EMS,ets

(2)For Laser machine order delivery,can be optional with terms of EXWork FOB,CNF,CIF By Air or by Sea based on the buyer's forwarders or ours.

FAQ

Q1.Are you a manufacturer?

A1: Yes, we are professional and experienced manufacturer with our own molds and production lines.

Q2.How about quality of products?

A2: Our technicians and QC teams test the products one by one using aging line, professional devices and instruments to ensure the quality for all products.

Q3.How about price?

A3: We are a manufacturer and always offer our customers the most competitive prices.

Q4.How to place an order?

A4: Contact with online service, or sent email to us directly, we will reply to you with product price, specifications, packing etc. soon. Thank you.

Q5.May I send material to test marking performance?

A5: Yes! You are welcome to send material to test our superior quality and service.

Q6.Can I visit your factory?

A6: Yes, welcome to visit our factory at your convenient time.

Q7.How can I make OEM or ODM orders?

A7: We have different print processing for different OEM/ODM orders. Please contact us with online service or send email to us directly.

Q8. How should I pay for my orders?

A8: You can pay by T/T would be available for qualified bank and MOQ required for each order.