

Product Information

Carmanhaas ([Telecentric Lens Factory China](#)) Telecentric scanning lenses are a special configuration in which the arrangement of optics are designed to focus the beam such that it is always perpendicular to the flat field. This is especially important for drilling applications such as via hole drilling in printed circuit boards, ensuring that the drilled holes are perpendicular to the surface even off the center of the scanning field. Welding and structuring applications can also benefit from the use of a telecentric lens, as the spot remains round, even along the edges of the field.

Telecentric scanning lenses are always multi-element designs and are supplied in a housing. At least one lens element will be larger than the field size to be scanned. In practice, this means that for reasons of manufacture and cost that only small field sizes are possible, in turn implying short focal lengths. Each specific application demands custom solutions for these lens types. Contact us with your specifications for a preliminary design and we will quote you.

Characteristics

1 High precision, small assembly error: $< 0.05\text{mm}$

2 High transmittance: $\geq 99.8\%$

3 High damage threshold: 10GW/cm^2

Carmanhaas Advantages:

(1) Made to custom requirements.

(2) Advanced in-house design, based on years of innovation in the field

Perpendicular beam for critical applications

Telecentric F-theta Scan Lenses



1030-1090nm Fiber Laser



532nm Green Laser



355nm UV Laser



Understand more: [Telecentric lens price china](#)

Technical Parameters:

1030-1090nm Telecentric F-Theta Scan Lenses

Part Description	FL(mm)	Scan Field (mm)	Max Entrance Pupil (mm)	Working Distance (mm)	Mounting Thread	Wavelength
TSL-(1030-1090)-50-100Q-(14CA)	100	50x50	14	140.5	M85x1	1030-1090nm
TSL-(1030-1090)-52-160-(14CA)	160	52x52	14	186	M79X1	
TSL-(1030-1090)-60-120-(15CA)	120	60x60	15	162	M85x1	
TSL-(1030-1090)-75-160-(14CA)	160	75x75	14	186	M85x1	

Optical System Layout

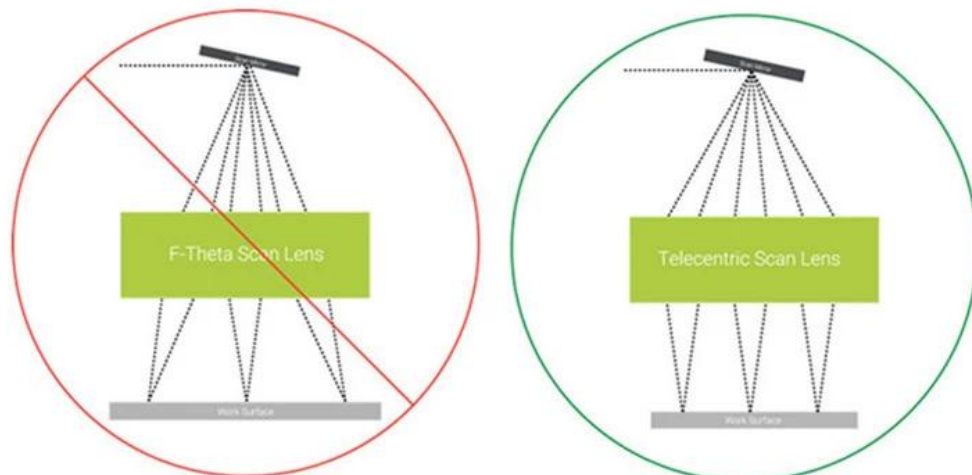
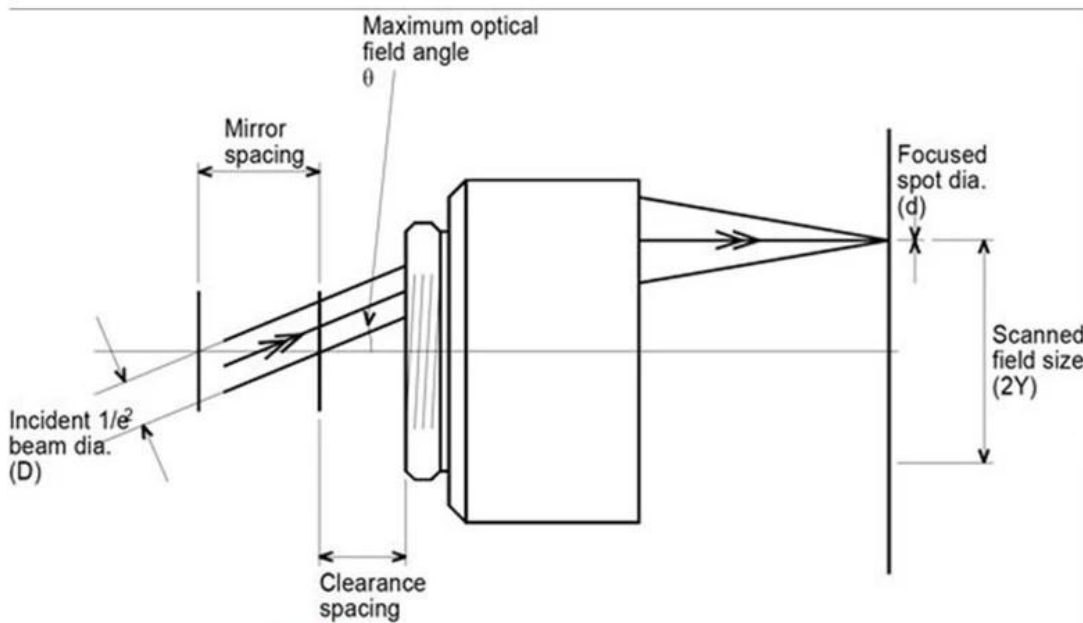

Figure 2: Non-telecentric vs. telecentric f-theta lenses.

Factory







重要仪器,
非专业人士勿动。

OptiCentric 300

TRIOPTICS





PerkinElmer Lambda 950---Testing Transmission and Reflectivity



Certificate&Exhibition





C E R T I F I C A T E

ATTESTATION CERTIFICATE OF MACHINERY AND LOW VOLTAGE DIRECTIVES

Technical file of the company mentioned below has been observed and audit has been completed successfully. 2006/42/EC Machinery Directive and 2014/ 35/EU Low Voltage Directive have been taken as references for these processes

Company Name : **Camman HAAS Laser Technology (Suzhou) Co., Ltd.**

Company Address : No 155, West Road Suhong, Suzhou Industrial Park, Suzhou City, Jiangsu , P.R.China

Related Directives and Annex : **Low Voltage Directive 2014/35/EU
Machinery Directive 2006/42/EC**

Related Standards : **EN ISO 12100:2010; EN 60204-1:2006+A1:2009+AC:2010**

Product Name : **Laser Marking Machine**

Report No and Date : **SD-90049717.09.08.2018**

Product Brand/Model/Type : **LMCH-3W,LMCH-5W,LMCH-10W,LMCH-15W,LMCH-20W,LMCH-25W,
LMCH-30W,LMCH-50W,LMCH-60W,LMCH-70W,LMCH-100W,
LMCH-120W,LMCH-150W,LMCH-200W,LMCH-300W,LMCH-500W**

Certificate Number : **M.2018.201.N6073**

Initial Assessment Date : **10.08.2018**

Registration Date : **13.08.2018**

Reissue Date/No :

Expiry Date : **12.08.2023**

Signature
UDEM International Certification
Auditing Training Centre Industry
and Trade Inc. Co.

The validity of the certificate can be checked through www.udem.com.tr. The CE mark shown on the right can only be used under the responsibility of the manufacturer with the completion of EC Declaration of Conformity for all the relevant Directives. This certificate remains the property of UDEM International Certification Auditing Training Centre Industry and Trade Inc. Co. to whom it must be returned upon request. The above-mentioned firm must keep a copy of this certificate for 15 years from the registration of certificate. This certificate only covers the product(s) stated above and UDEM must be notified in case of any changes on the product(s).
Address: Mithakere Mahallesi 2073 Sokak (Eski 93 Sokak) No:10 Çankaya - Ankara - TÜRKİYE
Phone: +90 0312 443 03 90 Fax: +90 0312 443 03 76
E-mail: info@udemtd.com.tr www.udem.com.tr



Certificate of Approval

Certificate No.: 10119Q12565ROM

Awarded to

**Carman Haas Laser Technology(SuZhou)
Co., Ltd.**

Organization Code Certificate No. / Unified Social Credit Code:91320594MA1MF4EP56
Add.:No.155, West Road Suhong, Suzhou Industrial Park, Suzhou City, Jiangsu Province, P.R. China. 215000

Beijing ZhongLianTianRun Certification Center (ZLTR) certify that the
Quality Management System of the above organization has been assessed and found to be
in accordance with the requirements of the standard:
GB/T19001-2016 / ISO9001:2015

SCOPE OF CERTIFICATION/REGISTRATION

The Research and Development and Production of Optics Lenses (Except the limits of national laws and regulations.)

This certificate is made valid when used with certification scopes and the requirements of applicable laws and regulations. These requirements include, but are not limited to, administrative permits, scopes of qualifications, and CCC requirements.

Subject to operation conditions in requirements conformity with Quality Management System.

This Certificate is valid for a period of three years only.

Date from: Mar 13th,2019 To: Mar 12th,2022

The effectiveness of this Certificate shall be Validated by periodic surveillance audit of ZLTR for maintenance.

Information of this certificate can be found on the official website of Beijing Zhonglian Tianrun Certification center (<http://www.zltr.com.cn>)



Beijing ZhongLiantianrun Certification Center

Room2003, 22nd Floor, 2nd Unit, Block 1, No.4 Yard, Qiyang Road, Chaoyang District, Beijing, P.R. China 100022

Information of the center can be found on the official website of Certification and Accreditation Administration of the People's Republic of China (<http://www.cnca.gov.cn>)

ISO 9001

ISO 9001

Packing List

Packaging & Shipping

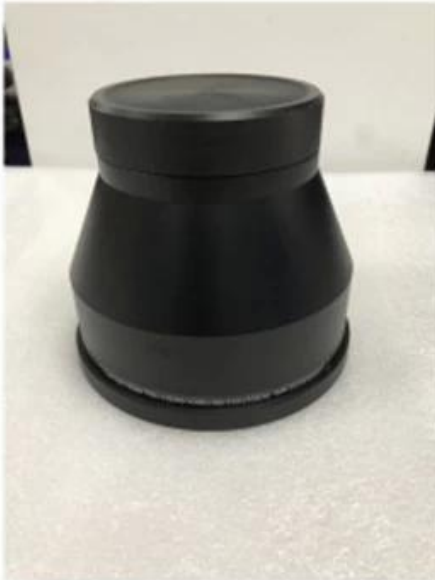



Return Policy:

Should returns be required:

Step 1) Contact us with this website email.

Step 2) Provide as much detail as possible about the problem you are having.

Step 3) Authorization to return the item will be issued.

Step 4) Return the item for the agreed replacement or refund.

Logistics:

(1)For Laser Optics order delivery,can be optional with DHL, UPS, FedEx, TNT, EMS etc

(2)For Laser machine order delivery, can be optional with terms of EXWork, FOB, CNF, CIF By Air or by Sea based on the buyer's forwarders or ours.

FAQ

Q1.Are you a manufacturer?

A1: Yes, we are professional and experienced [China Telecentric Lens Manufacturer](#) with our own molds and production lines.

Q2.How about quality of products?

A2: Our technicians and QC teams test the products one by one using aging line, professional devices and instruments to ensure the quality for all products.

Q3.How about price?

A3: We are a manufacturer and always offer our customers the most competitive prices.

Q4.How to place an order?

A4: Contact with online service, or sent email to us directly, we will reply to you with product price, specifications, packing etc. soon. Thank you.

Q5.May I send material to test marking performance?

A5: Yes! You are welcome to send material to test our superior quality and service.

Q6.Can I visit your factory?

A6: Yes, welcome to visit our factory at your convenient time.

Q7.How can I make OEM or ODM orders?

A7: We have different print processing for different OEM/ODM orders. Please contact us with online

service or send email to us directly.

Q8. How should I pay for my orders?

A8: You can pay by T/T would be available for qualified bank and MOQ required for each order.