

Descrição do Produto

Os componentes ópticos de corte de fibra de Carmamhaas são usados em vários tipos de cabeça de corte a laser de fibras, transmitindo e concentrando a saída do feixe da fibra para atingir a finalidade de cortar a folha. ([Lente de corte de cabeça raytool fábrica](#))

Características do produto:

- (1) Importado Material de Quartzo de Absorção Ultra Low Absorção
- (2) precisão da superfície: $\lambda / 5$
- (3) uso de energia: até 15000w
- (4) revestimento de absorção ultra-baixa, taxa de absorção <20ppm, long life time
- (5) Precisão de acabamento de superfície esférica até 0,2 μm



[Janela de lente de cabeça de corte a laser fabricante](#)

Capacidades de fabricação:

Especificações	
Material de substrato	Sílica fundida
Tolerância dimensional	+0.000 "-0,005"
Tolerância de espessura	$\pm 0,01$ "
Qualidade da superfície	40-20.
Paralelismo: (Plano)	≤ 1 ARC AINS

Capacidades de revestimento:

Especificações	
Standard ambos os lados AR revestimento @ 1070nm	
Absorção total	< 100PPM
Transmitância	> 99,9%

Janela de proteção de sílica fundida:

Diâmetro (mm)	Comprimento focal (mm)	Revestimento
18.	2.	Ar / ar @ 1030-1090nm
20.	2/3/4.	Ar / ar @ 1030-1090nm
21.5.	2.	Ar / ar @ 1030-1090nm
22.35.	4.	Ar / ar @ 1030-1090nm
24.9.	1.5.	Ar / ar @ 1030-1090nm
25.4.	4.	Ar / ar @ 1030-1090nm
27.9.	4.1.	Ar / ar @ 1030-1090nm
30.	1,5 / 5.	Ar / ar @ 1030-1090nm
32.	2/5.	Ar / ar @ 1030-1090nm
34.	5.	Ar / ar @ 1030-1090nm
35.	4.	Ar / ar @ 1030-1090nm
37.	1.5 / 1.6 / 7	Ar / ar @ 1030-1090nm
38.	1,5 / 2 / 6,35	Ar / ar @ 1030-1090nm
40.	2 / 2.5 / 3/5	Ar / ar @ 1030-1090nm
45.	3.	Ar / ar @ 1030-1090nm
50.	2/4.	Ar / ar @ 1030-1090nm
80.	4.	Ar / ar @ 1030-1090nm

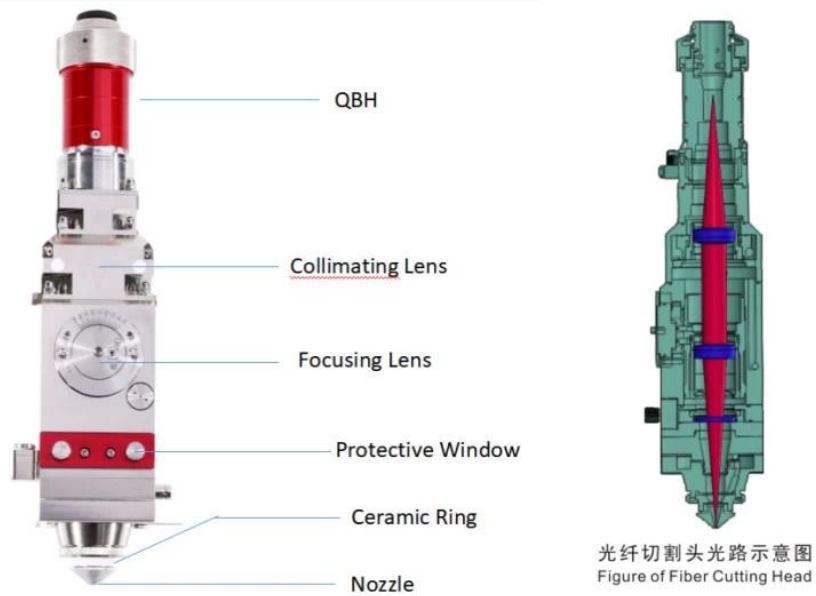

Installation Diagram

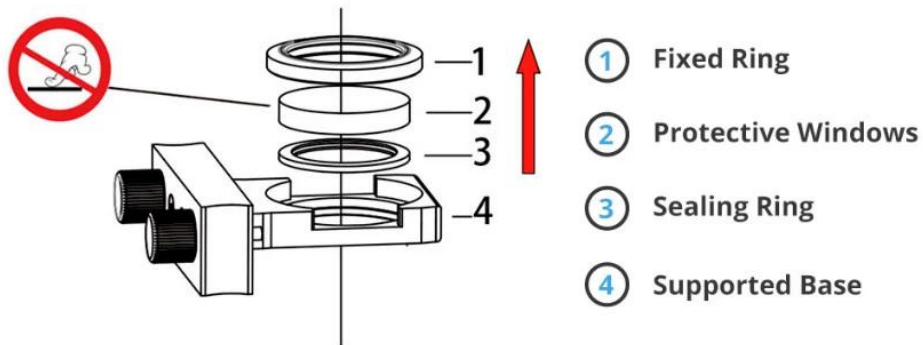

NOTICE: 1—3 Parts Should be taken out in the direction of the arrow, otherwise these parts will be damaged.

Janela protetora da lente de cabeça de corte a laser de fibra fábrica

Fábrica







重要仪器,
非专业人士勿动。

OptiCentric 300

TRIOPTICS





PerkinElmer Lambda 950---Testing Transmission and Reflectivity



Certificado e Exposição.



C E R T I F I C A T E

ATTESTATION CERTIFICATE OF MACHINERY AND LOW VOLTAGE DIRECTIVES

Technical file of the company mentioned below has been observed and audit has been completed successfully. 2006/42/EC Machinery Directive and 2014/ 35/EU Low Voltage Directive have been taken as references for these processes

Company Name : **Camman HAAS Laser Technology (Suzhou) Co., Ltd.**

Company Address : No 155, West Road Suhong, Suzhou Industrial Park, Suzhou City, Jiangsu , P.R.China

Related Directives and Annex : **Low Voltage Directive 2014/35/EU
Machinery Directive 2006/42/EC**

Related Standards : **EN ISO 12100:2010; EN 60204-1:2006+A1:2009+AC:2010**

Product Name : **Laser Marking Machine**

Report No and Date : SD-90049717.09.08.2018

Product Brand/Model/Type : LMCH-3W,LMCH-5W,LMCH-10W,LMCH-15W,LMCH-20W,LMCH-25W,
LMCH-30W,LMCH-50W,LMCH-60W,LMCH-70W,LMCH-100W,
LMCH-120W,LMCH-150W,LMCH-200W,LMCH-300W,LMCH-500W

Certificate Number : **M.2018.201.N6073**

Initial Assessment Date : 10.08.2018

Registration Date : 13.08.2018

Reissue Date/No :

Expiry Date : **12.08.2023**

Signature
UDM International Certification
Auditing Training Centre Industry
and Trade Inc. Co.



The validity of the certificate can be checked through www.udem.com.tr. The CE mark shown on the right can only be used under the responsibility of the manufacturer with the completion of EC Declaration of Conformity for all the relevant Directives. This certificate remains the property of UDEM International Certification Auditing Training Centre Industry and Trade Inc. Co. to whom it must be returned upon request. The above-mentioned firm must keep a copy of this certificate for 15 years from the registration of certificate. This certificate only covers the product(s) stated above and UDEM must be notified in case of any changes on the product(s).
Address: Murkazeri Mahallesi 2073 Sokak (Eski 93 Sokak) No:10 Çankaya - Ankara - TÜRKİYE
Phone: +90 0312 443 03 90 Fax: +90 0312 443 03 76
E-mail: info@udemtd.com.tr www.udem.com.tr



Certificate of Approval

Certificate No.: 10119Q12565R0M

Awarded to

**Carman Haas Laser Technology(SuZhou)
Co., Ltd.**

Organization Code Certificate No. / Unified Social Credit Code:91320594MA1MF4EP56
Add.:No.155, West Road Suhong, Suzhou Industrial Park, Suzhou City, Jiangsu Province, P.R. China. 215000

Beijing ZhongLianTianRun Certification Center (ZLTR) certify that the
Quality Management System of the above organization has been assessed and found to be
in accordance with the requirements of the standard:
GB/T19001-2016 / ISO9001:2015

SCOPE OF CERTIFICATION/REGISTRATION

The Research and Development and Production of Optics Lenses (Except the limits of national laws and regulations.)

This certificate is made valid when used with certification scopes and the requirements of applicable laws and regulations. These requirements include, but are not limited to, administrative permits, scopes of qualifications, and CCC requirements.

Subject to operation conditions in requirements conformity with Quality Management System.

This Certificate is valid for a period of three years only.

Date from: Mar 13th,2019 To: Mar 12th,2022

The effectiveness of this Certificate shall be Validated by periodic surveillance audit of ZLTR for maintenance.

Information of this certificate can be found on the official website of Beijing Zhonglian Tianrun Certification center (<http://www.zltr.com.cn>)

ISO 9001

ISO 9001



Beijing ZhongLiantianrun Certification Center

Room2003, 22nd Floor, 2nd Unit, Block 1, No.4 Yard, Qiyang Road, Chaoyang District, Beijing, P.R. China 100022

Information of the certificate can be found on the official website of Certification and Accreditation Administration of the People's Republic of China (<http://www.cnca.gov.cn>)



EmbalagemLista

Packaging & Shipping

Packaging 1



Packaging 2



Packaging 3



Shipping 4





Política de devolução:

Deve retornar ser necessário:

Passo 1) Entre em contato com este site e-mail.

Passo 2) Forneça o máximo de detalhes possível sobre o problema que você está tendo.

Etapa 3) Autorização para devolver o item será emitida.

Passo 4) Retorna o item para a substituição ou reembolso acordado.

Logística:

(1) Para a entrega do pedido de óptica a laser, pode ser opcional com DHL, UPS, FedEx, TNT, EMS, ETS

(2) paraLasermáquinapedidoEntrega, Can.seropcionalcomtermos.doEx trabalhoFob, cnf, cifPorArouporMarSediadasobreacompradorexpeditoresounosso.

Perguntas frequentes

Q1. Emar você é um fabricante?

A1: Sim, somos fabricante profissional e experiente com nossos próprios moldes e linhas de produção.

Q2. Como sobre a qualidade dos produtos?

A2: Nossos técnicos e equipes de QC testam os produtos um por um usando linha de envelhecimento, dispositivos profissionais e instrumentos para garantir a qualidade de todos os produtos.

Q3. Como sobre o preço?

A3: Somos um fabricante e sempre oferecemos aos nossos clientes os preços mais competitivos.

Q4. Como colocar um pedido?

A4: Entre em contato com o serviço on-line, ou envie um e-mail para nós diretamente, nós responderemos a você com preço do produto, especificações, embalagem etc. em breve. Obrigada.

Q5. may eu envio material para testar o desempenho de marcação?

A5: Sim! Você é bem-vindo para enviar material para testar nossa qualidade e serviço superiores.

Q6. Posso visitar sua fábrica?

A6: Sim, bem-vindo a visitar nossa fábrica no seu tempo conveniente.

Q7. Como posso fazer ordens de OEM ou ODM?

A7: Temos um processamento de impressão diferente para diferentes OEM / ODMers. Por favor, entre em contato conosco com serviço on-line ou envie um email para nós diretamente.

Q8. Como devo pagar pelos meus pedidos?

A8: Você pode pagar por T / T estaria disponível para banco qualificado e MOQ necessário para cada

pedido.